

# Canalta

**Flow Measurement**

A Canalta Controls Company

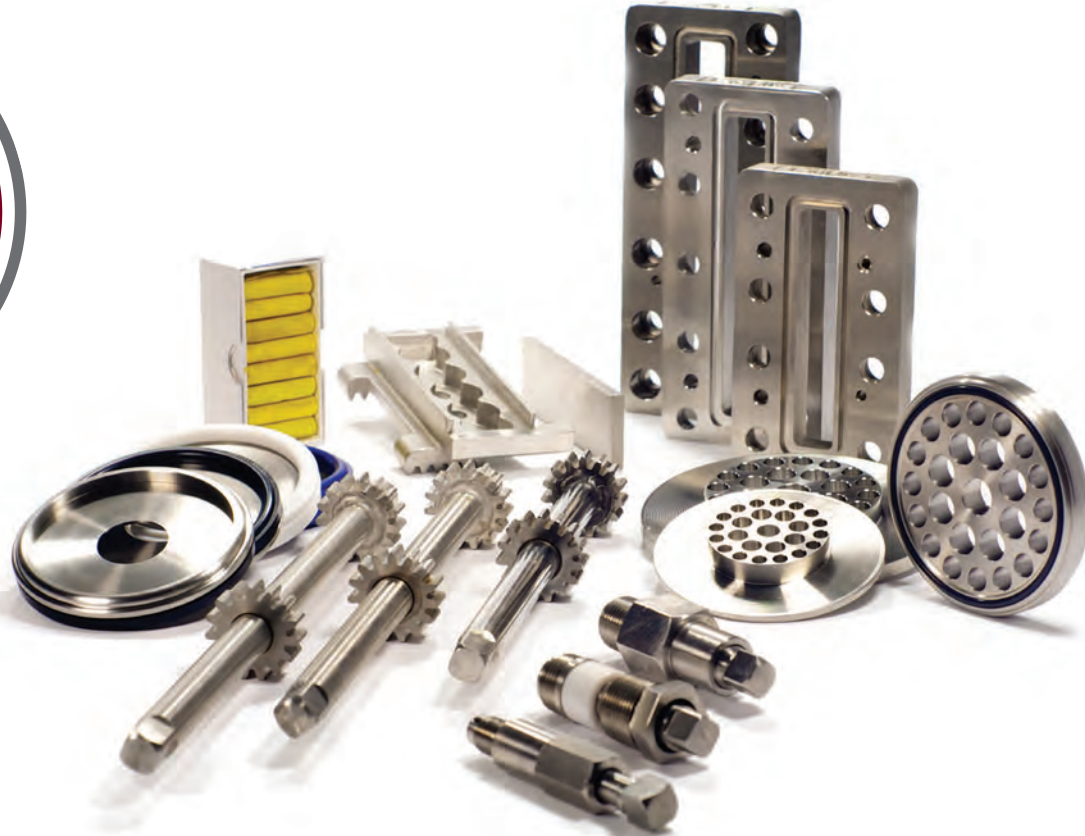

## Canalta Orifice Fitting Parts & Accessories

*Precision Machined for Accuracy, Reliability and Performance*

**Call Us Toll Free: 1-855-CANALTA**

An ISO 9001:2015 registered company

Phone: 403.342.4494

Email: [sales@canaltaflow.com](mailto:sales@canaltaflow.com)

[www.canaltaflow.com](http://www.canaltaflow.com)

**Canalta Flow Measurement** is a privately held Canadian company that began operations in 1986 as an instrumentation and electrical contractor. Since 1991, the focus has been on the manufacture of industrial control and measurement equipment. The company now manufactures and services several product lines specifically targeting the oil and gas industries, and supplies product across North America, South America, Asia and the Middle East. Canalta has grown to include primary manufacturing and warehousing facilities in Red Deer Alberta (Canada), Coimbatore (India), Incheon (Korea) and Denton, Texas, (USA), direct sales offices in Buenos Aires (Argentina), Norfolk (United Kingdom), India and Singapore, with an extensive global distribution network.



## Quality Matters

When you are in the market for parts, trust the **OEM**. The quality of Canalta Orifice Fitting parts and accessories is our top priority. As standard our internal components are made from SS316 offering (stainless steel), providing reliability and performance over a long service life. These parts conform to NACE MR0175 / ISO 15156 specifications.

Our SS316 internals protect against mass loss due to general or localized corrosion and are ideal for extreme corrosive applications, such as wet H<sub>2</sub>S service.

Standard plate seals and fitting O-rings are made of HNBR rubber, offering first-class compression set, tearing and abrasion performance, as well as excellent chemical resistance in oilfield applications, including H<sub>2</sub>S and CO<sub>2</sub>.

Wherever possible, Canalta has endeavoured to ensure that our parts and accessories offerings are interchangeable with the current industry standard orifice fitting brand, making Canalta Orifice Fitting parts and accessories suitable for re-builds and re-works of our competitors' product lines.

All materials meet the applicable ASTM requirements and are traceable to the foundry. Orifice plates and flow conditioners comply with AGA 3.2 specifications. Manufacturing at Canalta conforms to ASME codes B31.3, B16.5 and B16.34 latest revisions.

Close attention to detail and tight quality control auditing ensure that your Canalta Orifice Fitting parts and accessories are reliable and ready for service in any application.



*PARTS FOR 2" - 6" SINGLE CHAMBER FITTINGS*

4

Orifice Fitting Diagrams ..... 6

Parts Variable by Model Size ..... 7

Common Parts for All Model Sizes ..... 9

*PARTS FOR 2" - 10" 10,000 PSI SINGLE CHAMBER FITTINGS*

10

Orifice Fitting Diagrams ..... 12

*PARTS FOR ALL DBB, DUAL CHAMBER AND 8"+ SINGLE CHAMBER FITTINGS*

14

8"+ Single Chamber Fitting Diagrams ..... 16

Dual Chamber and DBB Fiting Diagrams ..... 18

Spare Parts for all DBB , Dual Chamber and 8"+ Single Chambers ..... 34

Orifice Fitting Repair Kits ..... 36

Parts Variable by Model Size ..... 38

Common Parts for All Model Sizes ..... 46

*ORIFICE PLATES & PLATE SEALS*

54

Orifice Plate Seals ..... 56

Orifice Plates ..... 60

*FLOW CONDITIONING SOLUTIONS*

66

Contour™ Flow Conditioners ..... 68

Contour™ Flange & Pin style Flow Conditioners ..... 70

Contour™ FCH Flow Conditioner Housings ..... 72

FCH Single Chamber Flow Conditioner Housings Diagrams ..... 74

Parts Variable by Model Size & Common Parts for All Model Sizes ..... 76

FCH Dual Chamber Flow Conditioner Housings Diagrams ..... 80

Parts Variable by Model Size & Common Parts for All Model Sizes ..... 84

Contour™ Vane Flow Straighteners ..... 88







***PARTS FOR  
2" - 6" SINGLE CHAMBER  
ORIFICE FITTINGS***

**2" - 6" SINGLE CHAMBER ORIFICE FITTING PARTS**

Part	Qty.	Description
04	1	Flangeneck Body
05	2	Plate Carrier Bolt
5A	2	Lock Washer
06	1	Seal Bar Alignment Pin
07	1	Plate Carrier Alignment Pin
8G	1	Plate Carrier
*8H	1	Seal Ring
*8K	1	"K" Style Retaining Ring
9G	1	Seal Bar
9B	1	Seal Bar O-ring
11	A/R	Clamping Bar Screw
12	1	Clamping Bar
13	1	Orifice Plate
30	1	Drain Plug
31	4	Meter Tap Plug (Qty 8 with teletaps)
50	1	Specification Plate

A/R = As Required per Model Size

Speciality Material Not Listed Available Upon Request

\*Other types of orifice plate seals are available upon request

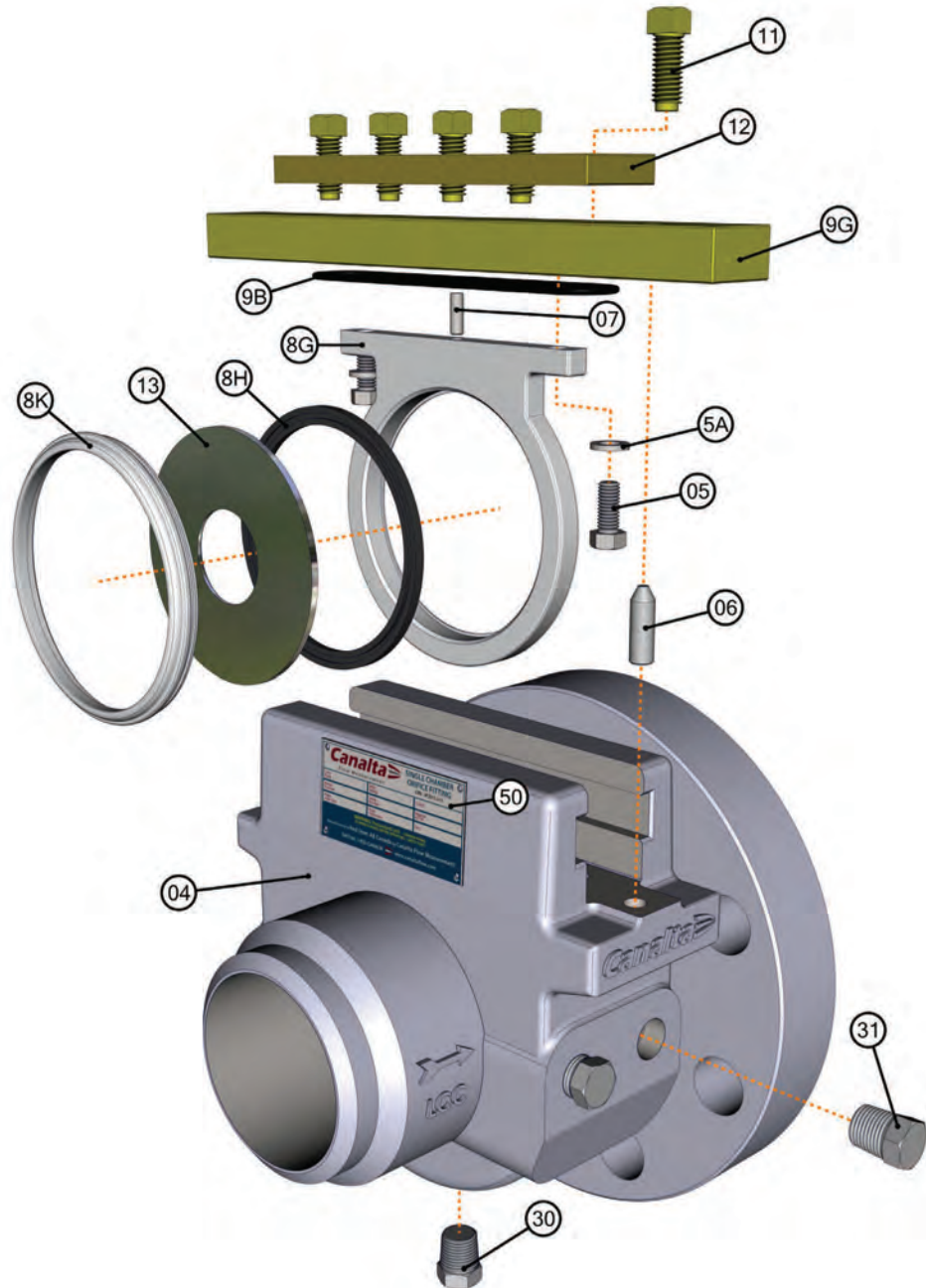



VARIABLE BY MODEL SIZE

#8G Plate Carrier



Available in CF8M cast stainless steel.

*If 85 Edition parts are required, replace "92-SS" with "85-SS" (applicable for Standard non-notched only)*

CF8M Stainless Steel

Size (Inches)	Part Number (Standard non-notched)	Part Number (Standard notched)	Notes
2	260SC08-92-SS	260SC08CN-92-SS	
3	360SC08-92-SS	360SC08CN-92-SS	
4	460SC08-92-SS	460SC08CN-92-SS	
6	660SC08-92-SS	660SC08CN-92-SS	

#9G Seal Bar



Available for 150 - 900 or 1500 /2500 ANSI ratings in 1018 YZP carbon steel and stainless steel option. Requires one seal bar O-ring (#9B).

150 - 900 ANSI		1500/2500 ANSI	
Size (Inches)	Part Number	Part Number	Notes
2	260SC09G	2250SC09G	
3	360SC09G	3250SC09G	
4	460SC09G	4250SC09G	
6	660SC09G	6250SC09G	

YZP = Yellow Zinc Plated



## #9B Seal Bar O-ring



HNBR Rubber

Size (Inches)	Part Number	Notes
2	O241-80H	
3	O245-80H	
4	O250-80H	
6	O259-80H	

## #12 Clamping Bar

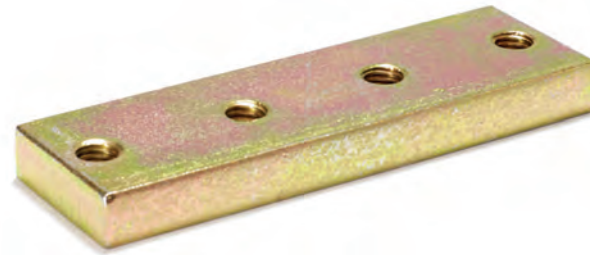

Available for 150 - 900 or 1500/2500 ANSI ratings in 1018 YZP carbon steel and stainless steel option. Requires corresponding clamping bar screws (#11).

150 - 900 ANSI			1500 / 2500 ANSI	
Size (Inches)	Part Number	Notes	Part Number	Notes
2	260SC12		2250SC12	
3	360SC12		3250SC12	
4	460SC12		4250SC12	
6	660SC12		6250SC12	



**COMMON TO ALL MODEL SIZES**

Item	Part Number	Material	Description	Notes
05	C60SC05	316 SS	Plate Carrier Bolt 	
5A	C60SC05A	316 SS	Plate Carrier Lock Washer 	
06	C60SC51	304 SS or 316 SS	Seal Bar Alignment Pin 	
07	C60SC07	316 SS	Plate Carrier Alignment Pin 	
11 ★	BSQNC-FT-0.500-13-1.250-CS-ZY	Case Hardened 4140 CS	Clamping Bar Screw (150-900 ANSI) 	
11 ★	BSQNC-FT-0.625-11-2.500-CS-ZY	Case Hardened 4140 CS	Clamping Bar Screw (1500/2500 ANSI) 	
30	PP3/4-A105N or PP3/4-A350	A105 CS or A350 CS	Drain Plug - 3/4" NPT 	
31	PP1/2-A105N or PP1/2-A350	A105 CS or A350 CS	Meter Tap & Drain Plug - 1/2" NPT 	
50	CSC50	Color Etched 316 SS	Specification Plate 	

(Stainless Steel option available on most parts)





***PARTS FOR  
10,000 PSI SINGLE CHAMBER  
ORIFICE FITTINGS***

## 10,000 PSI SINGLE CHAMBER ORIFICE FITTING PARTS

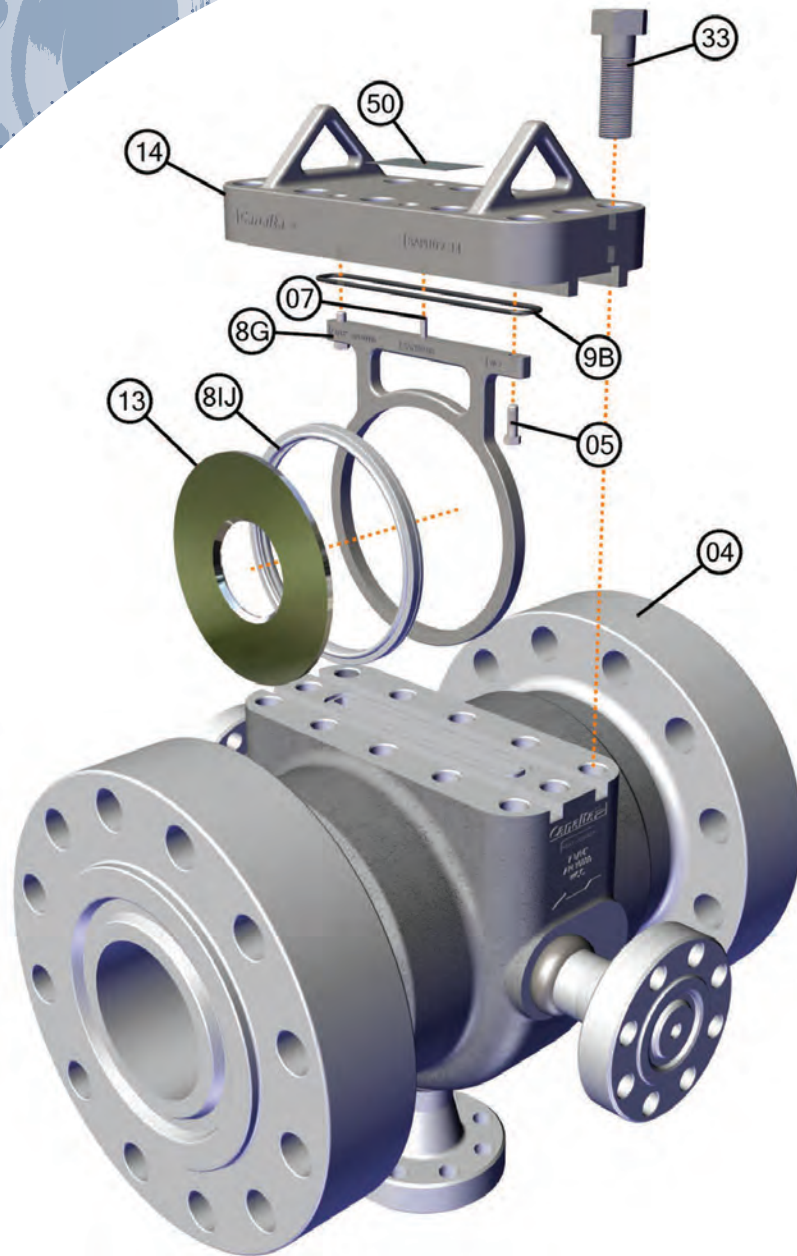

Part	Qty.	Description
04	1	Flange x Flange Body
05	2	Plate Carrier Bolt
07	1	Plate Carrier Alignment Pin
8G	1	Plate Carrier
*8IJ	1	Teflon Snap Seal Set
9B	1	Seal Bar O-ring
13	1	Orifice Plate
14	1	Top Casting
33	A/R	Body Screw
50	1	Specification Plate

A/R = As Required per Model Size

\* Other types of orifice plate seals are available upon request



VARIABLE BY MODEL SIZE

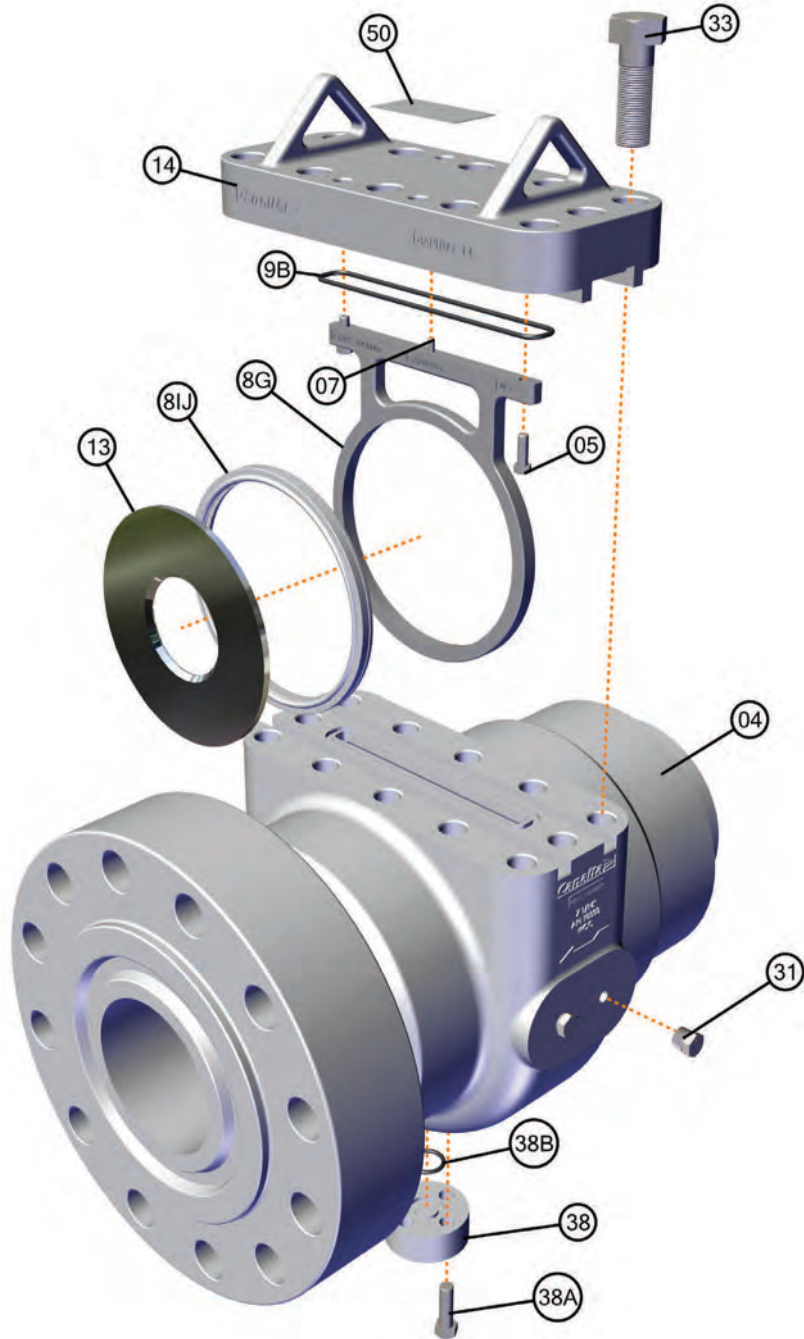

Item	Qty.	Description
04	1	Flangeneck Body
05	2	Plate Carrier Bolt
07	1	Plate Carrier Alignment Pin
8G	1	Plate Carrier
*8IJ	1	Teflon Snap Seal Set
9B	1	Seal Bar O-Ring
13	1	Orifice Plate
14	1	Top Casting
31	A/R	Hex Head DP Plug
33	A/R	Body Screw
38	1	Drain Cap
38A	4	Drain Cap Screw
38B	1	Drain Cap O-Ring
50	1	SC Specification Plate

A/R = As Required per Model Size

\* Other types of orifice plate seals are available upon request







***PARTS FOR ALL  
8"+ SINGLE CHAMBER  
ORIFICE FITTINGS***



## 8" - 16" SINGLE CHAMBER ORIFICE FITTINGS

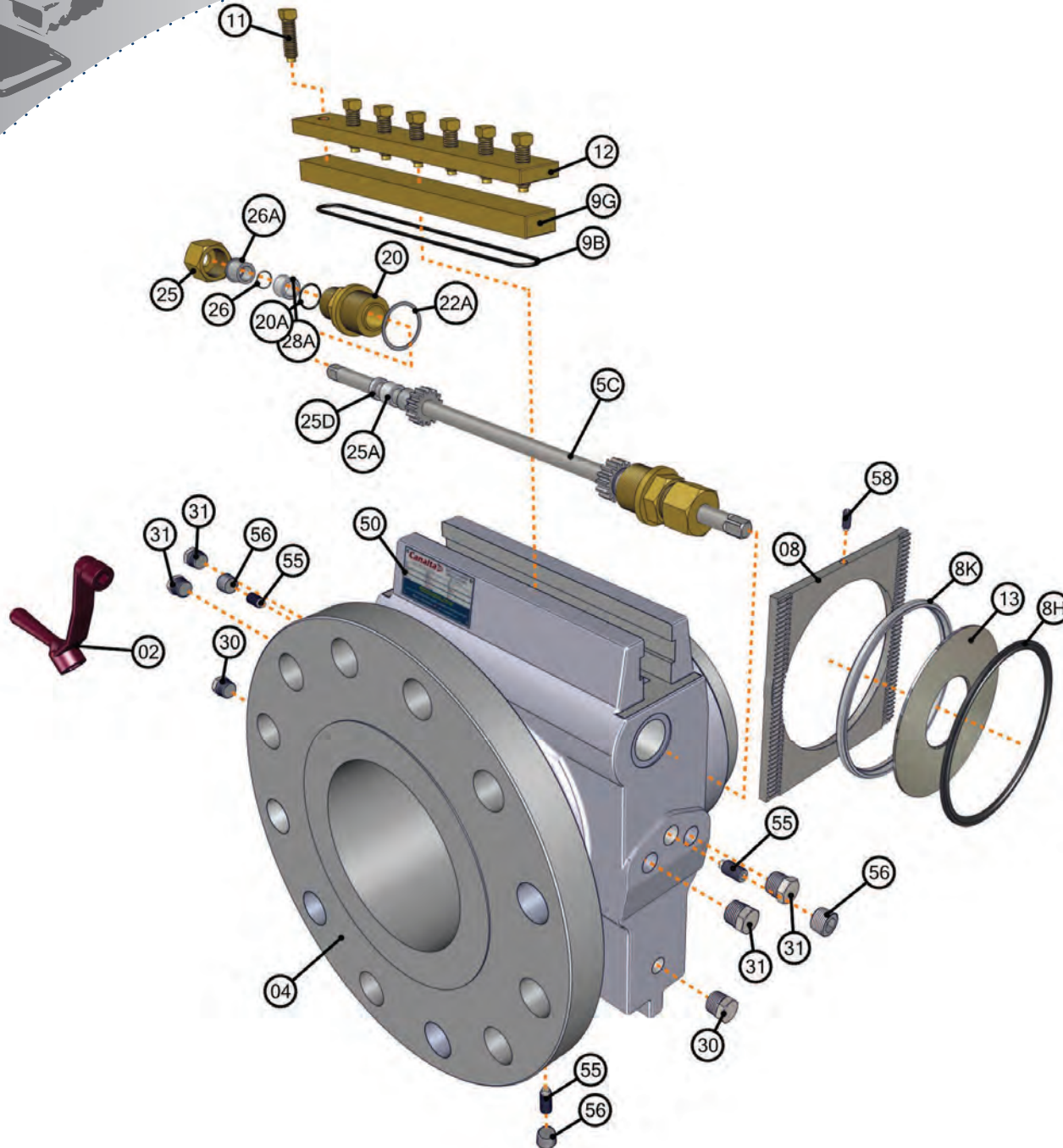

Part	Qty.	Description
02	1	Operating Wrench
04	1	Flangeneck Body
5C	1	Dual Shaft and Pinion Gear
08	1	Plate Carrier
* 8H	1	Seal Ring
* 8K	1	"K" Style Retaining Ring
9B	1	Seal Bar O-ring
9G	1	Seal Bar
11	A/R	Clamping Bar Screw
12	1	Clamping Bar
13	1	Orifice Plate
20	1	Stuffing Box
20A	1	Stuffing Box Outer Gland Seal
22A	2	Stuffing Box Gasket
25	1	Packing Nut
25A-F	A/R	Packing Sleeve
25S2	1	Complete Packing Set
26	1	Stuffing Box Gland
26A	1	Stuffing Box Inner Gland Seal
28A	1	Bushing Retainer
30	2	Drain Plug
31	4	Meter Tap Plug
50	1	Specification Plate
55	3	Eccentricity Alignment Pin
56	3	Eccentricity Alignment Pin Plug
58	1	Plate Carrier Alignment Screw

A/R = As Required per Model Size

\* Other types of orifice plate seals are available upon request

# 18"+ SINGLE CHAMBER ORIFICE FITTINGS

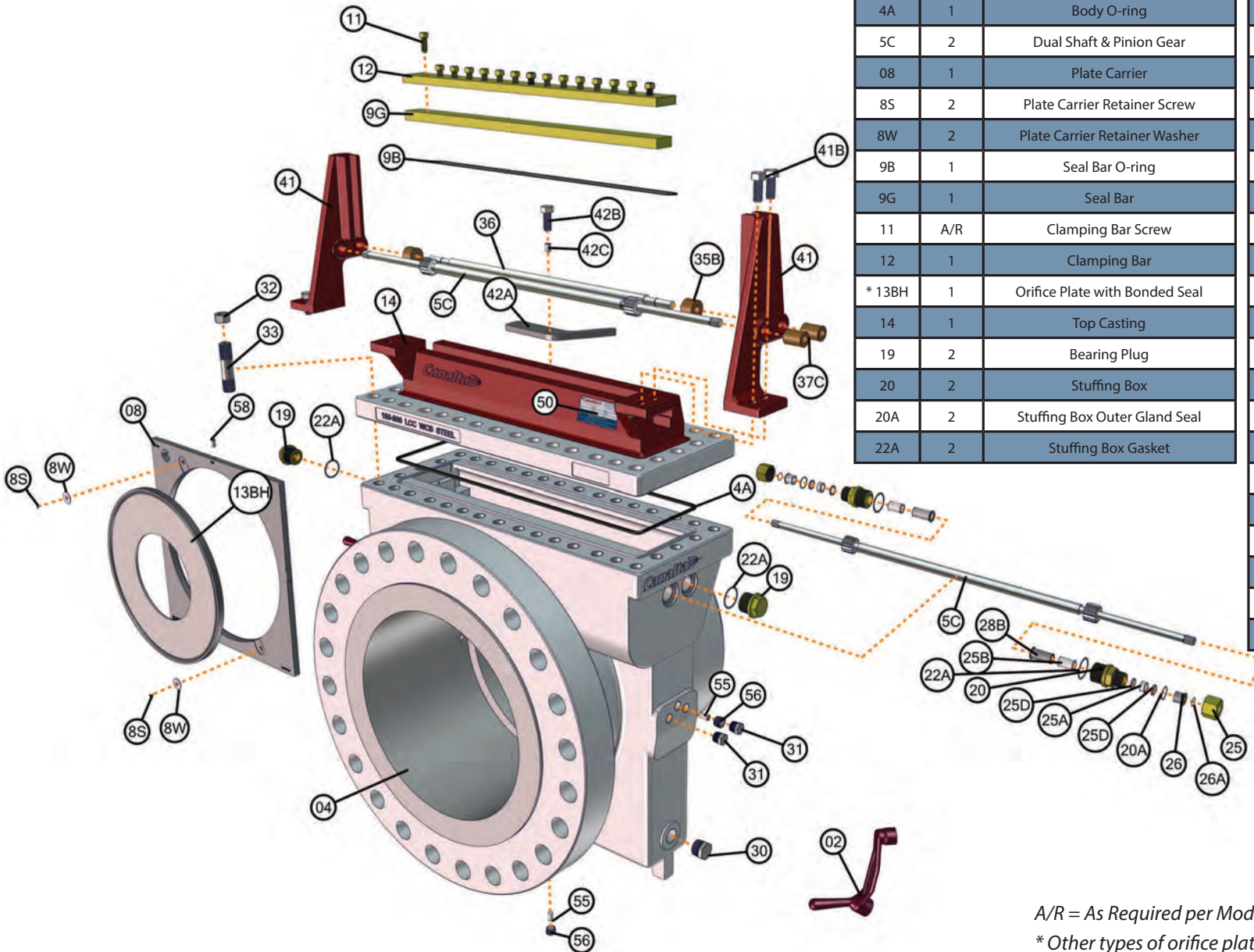

Part	Qty.	Description
02	1	Operating Wrench
04	1	Flangeneck Body
4A	1	Body O-ring
5C	2	Dual Shaft & Pinion Gear
08	1	Plate Carrier
8S	2	Plate Carrier Retainer Screw
8W	2	Plate Carrier Retainer Washer
9B	1	Seal Bar O-ring
9G	1	Seal Bar
11	A/R	Clamping Bar Screw
12	1	Clamping Bar
* 13BH	1	Orifice Plate with Bonded Seal
14	1	Top Casting
19	2	Bearing Plug
20	2	Stuffing Box
20A	2	Stuffing Box Outer Gland Seal
22A	2	Stuffing Box Gasket

Part	Qty.	Description
25	1	Packing Nut
25A-F	A/R	Packing Sleeve
25S2	1	Complete Packing Set
26	1	Stuffing Box Gland
26A	1	Stuffing Box Inner Gland Seal
28B	1	Bushing Retainer
30	2	Drain Plug
31	4	Meter Tap Plug
32	A/R	Body Hex Nuts
33	A/R	Body Stud
35B	2	External Shaft Roller
36	1	External Shaft
37C	4	Shaft Busing
41	2	Plate Carrier Guide (Left/Right)
41B	4	Plate Carrier Bolt
42A	1	Plate Carrier Stop
42B	1	Plate Carrier Stop Bolt
42C	1	Plate Carrier Stop Bushing
50	1	Specification Plate
55	3	Eccentricity Alignment Pin
56	3	Eccentricity Alignment Pin Plug
58	1	Plate Carrier Alignment Screw
70	1	Gear Shaft Assembly

A/R = As Required per Model Size

\* Other types of orifice plate seals are available upon request



**Canalta** 

*Flow Measurement*

An ISO 9001:2015 Registered Company





***PARTS FOR ALL  
DUAL CHAMBER &  
DBB ORIFICE FITTINGS  
ORIFICE FITTINGS***

# **LOOK LIKE A FAMILIAR PROBLEM?**

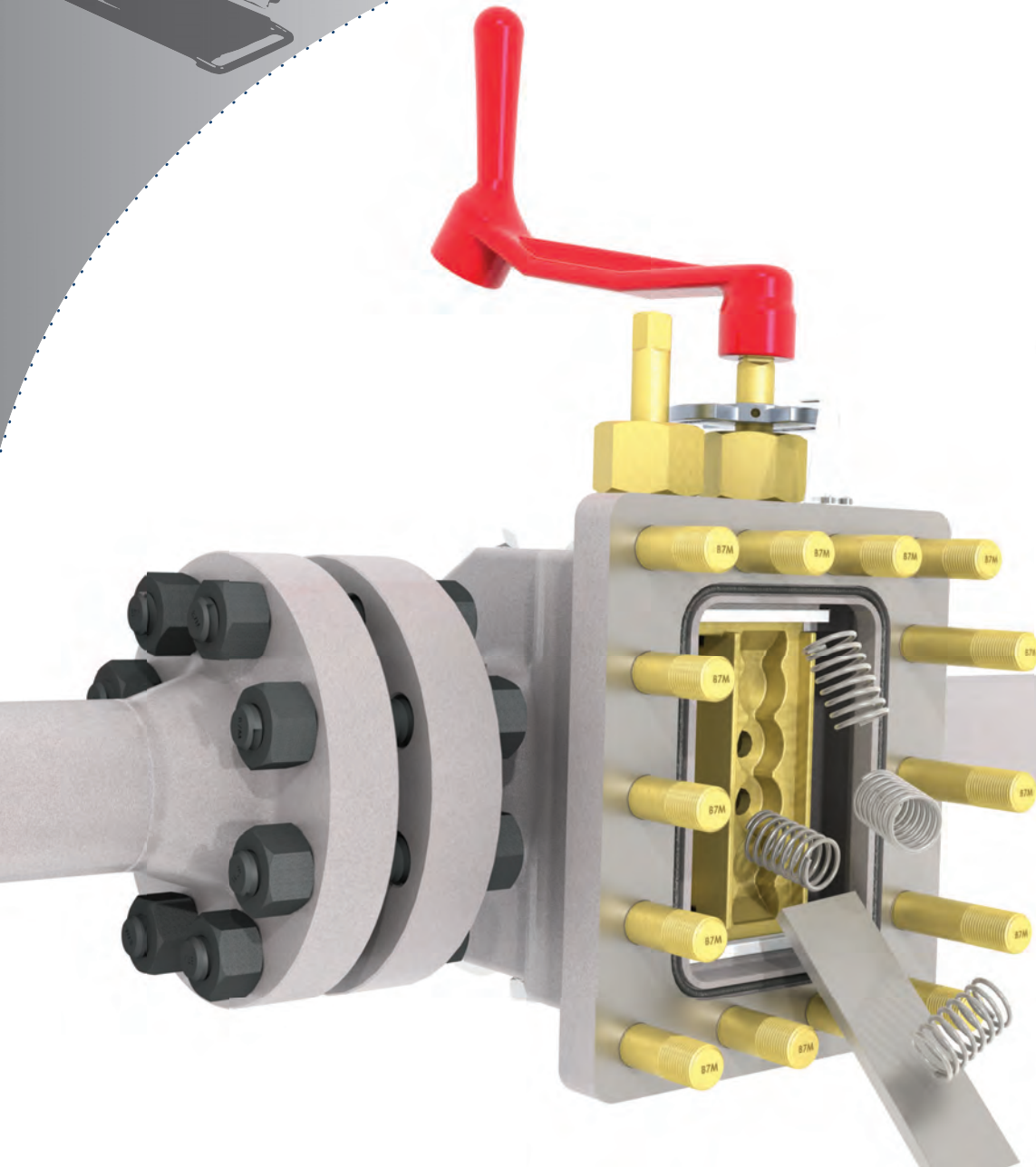

The vast majority of orifice fittings in service in North America are in vertical flow or rotated installations, and anyone who has worked with these units knows the frustration of reassembly after maintenance. Valve components shift out of position, the valve strip is misaligned or the assembly falls out of the body completely.

That's why Canalta developed the **CLIP-STYLE VALVE CARRIER**, a unique package that holds the valve carrier, springs and valve strip together without affecting the critical performance of the slide valve as a whole. These units are already in service worldwide and can improve your field operations as well.

Say goodbye to misaligned or damaged valve strips. Say goodbye to using two pounds of grease to reassemble the orifice meter after maintenance. Available as a retrofit for all existing Canalta and Daniel® Senior® orifice fittings, and shipping as the standard valve carrier configuration in new Canalta DC, DBB and DC FCH units from March 2014, **Canalta's Clip-style Valve Carrier** makes reassembly both faster and easier than ever before.



Patent Pending

AVAILABLE TO  
RETROFIT YOUR  
EXISTING CANALTA  
AND DANIEL®  
ORIFICE METERS  
USE SUFFIX DC90 TO GET FULL  
REPLACEMENT ASSEMBLIES

NOTE: Daniel® and Senior® are registered trademarks of Daniel Industries, Inc. Daniel Industries, Inc. is not affiliated with Canalta Flow Measurement in any manner. Daniel Industries has not reviewed, sanctioned or endorsed any products manufactured, reconditioned, sold or marketed by Canalta Flow Measurement.



**2" - 14" DUAL CHAMBER ORIFICE FITTINGS**

**80 - VALVE SEAT ASSEMBLY**

**01 - EQUALIZER ASSEMBLY**



**23 - GREASE GUN ASSEMBLY**  
(Used only on Grease Type Seat)

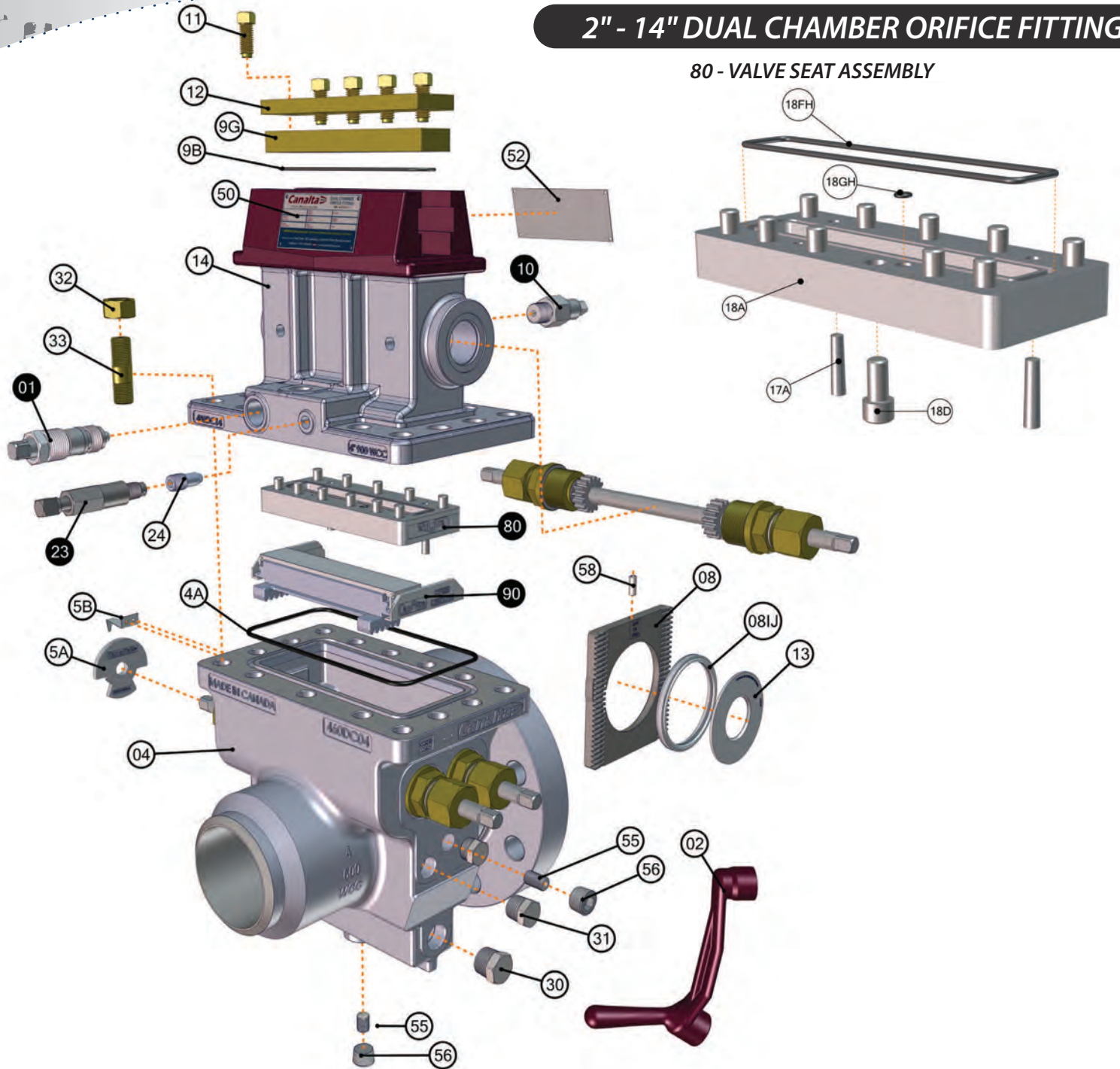
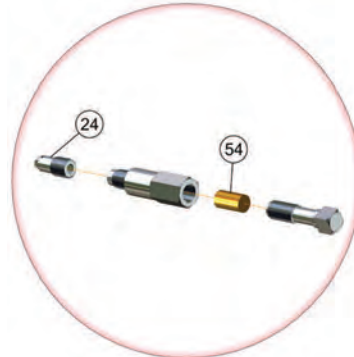

**70 - GEAR SHAFT COMPONENTS**

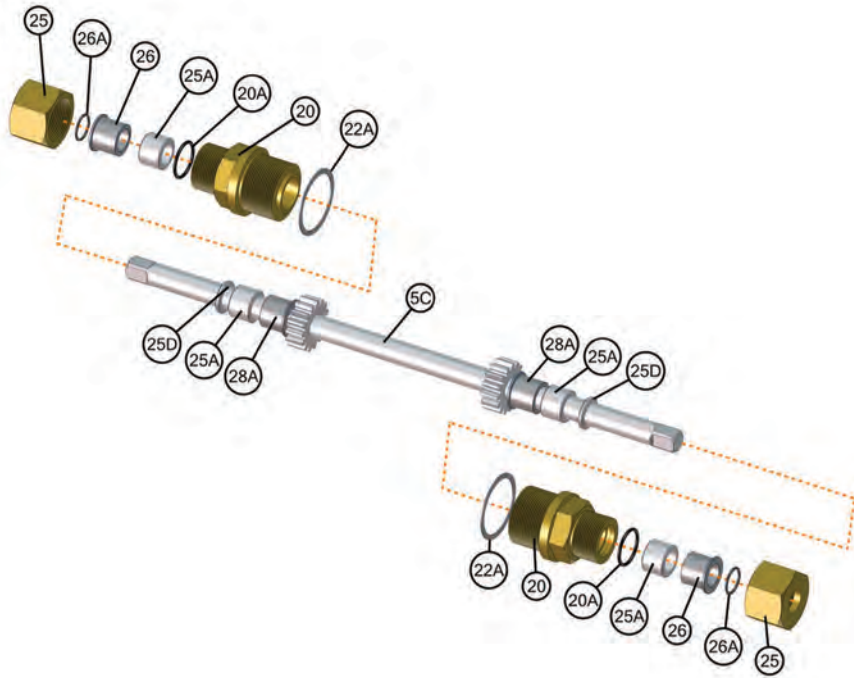

**90 - CLIPPER VALVE ASSEMBLY**

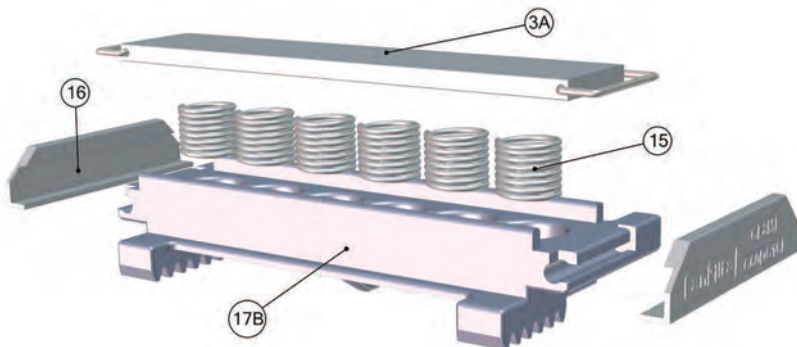

Part	Qty.	Description
01	1	Equalizer Valve Assembly
1G	1	Equalizer Valve Stem
1H	1	Equalizer Valve Packing Nut
1D	1	Equalizer Ball
1K	1	Equalizer Packing Washer
1J	1	Equalizer Packing
02	1	Operating Wrench
3A	1	Clip Style Valve Strip
04	1	Flange x Flange Body
4A	1	Body O-ring
5C	3	Dual Shaft & Pinion Gear
5A	1	Slide Valve Indicator Plate
5B	1	Slide Valve Indicator Pointer
08	1	Plate Carrier
** 8K	1	"K" Style Retaining Ring
** 8H	1	Seal Ring
9G	1	Seal Bar with O-ring Groove
9B	1	Seal Bar O-ring
10C	1	Bleeder Valve Body
10D	1	Bleeder Valve Needle
10E	1	Bleeder Valve O-ring
10G	1	Bleeder Valve Set Screw
11	A/R	Clamping Bar Screw
12	1	Clamping Bar
13	1	Orifice Plate
14	1	Top Housing
15	A/R	Valve Spring
16	2	Valve Carrier Guide
17B	1	Valve Carrier

A/R = As Required per Model Size

\* Not Applicable for Soft Seat design

\*\* Other types of orifice plate seals are available upon request

Part	Qty.	Description
17A	2	Valve Carrier Stop Pins
18A*/B	1	Valve Seat (Grease* /Soft)
18D	A/R	Valve Seat Screws
18FH	1	Valve Seat Top O-ring
18GH*	1	Valve Seat Grease Port Seal
19	3	Bearing Plug
20	3	Stuffing Box
20A	3	Stuffing Box Outer Gland Seal
22A	6	Stuffing Box Gaskets
* 23	1	Grease Gun Assembly
* 23A	1	Grease Gun Stem
* 23B	1	Grease Gun Body
24	1	Double Ball Grease Check Valve
25	3	Packing Nut
25A-F	A/R	Packing Sleeve
25S2	1	Complete Packing Set
26	3	Stuffing Box Glands
26A	3	Stuffing Box Inner Gland Seal
28A	3	Bushing Retainer - Stuffing Box
30	2	Drain Plug
31	4	Meter Tap Plug (Qty = 8 with teletaps)
32	A/R	Body Hex Nuts
33	A/R	Body Studs
50	1	Specification Plate
52	1	Operating Instruction Plate
* 54	A/R	Slide Valve Lubricant
55	3	Eccentricity Alignment Pin
56	3	Eccentricity Alignment Plugs
58	1	Plate Carrier Alignment Screw



## 16" DUAL CHAMBER ORIFICE FITTINGS

01 - EQUALIZER ASSEMBLY



23 - GREASE GUN ASSEMBLY  
(Used only on Grease Type Seat)



80 - VALVE SEAT ASSEMBLY

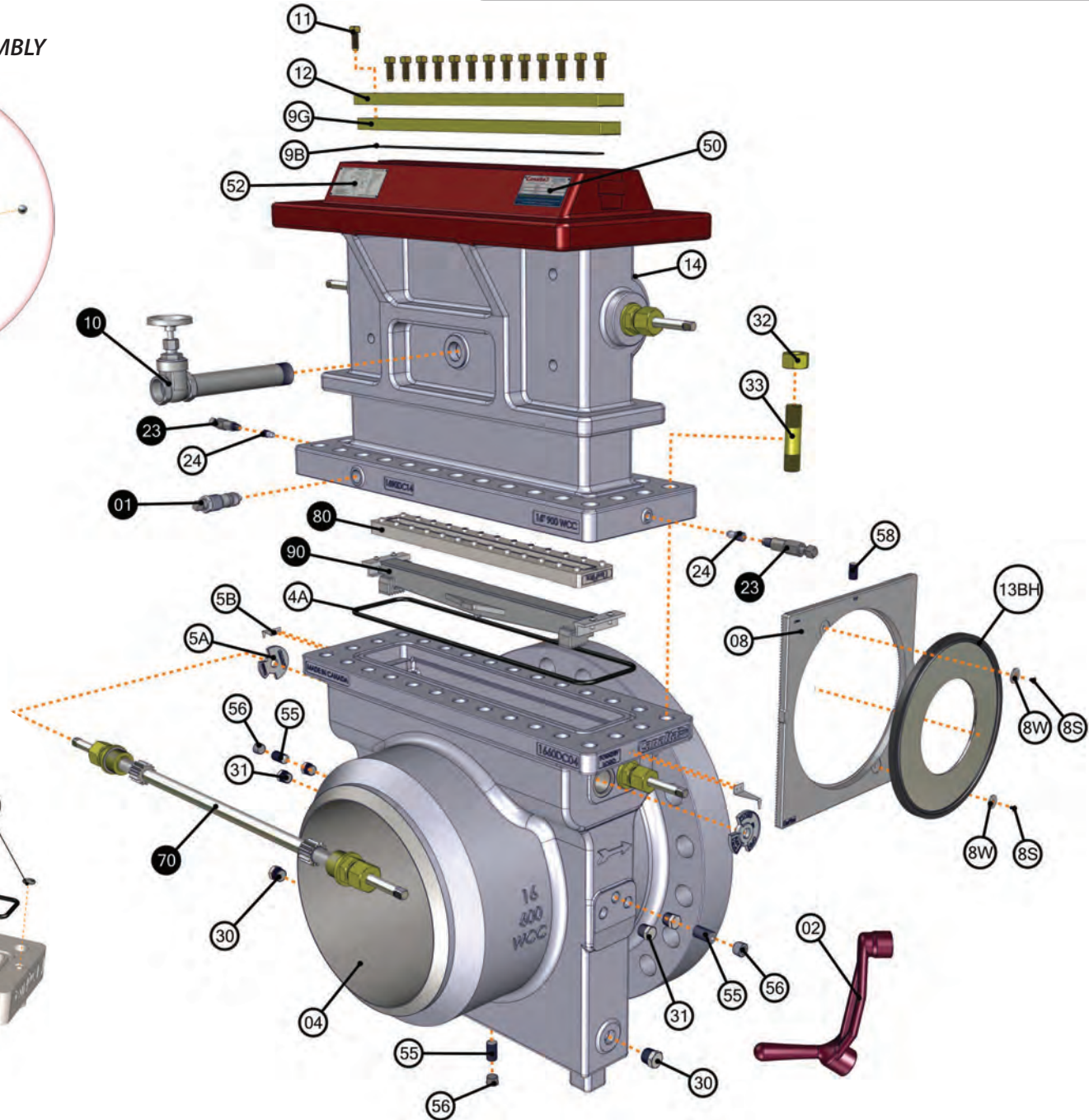
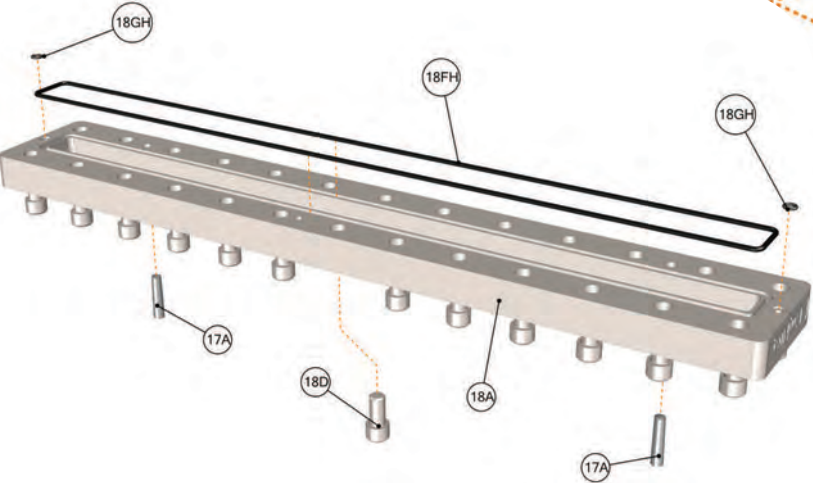



**70 - GEAR SHAFT COMPONENTS**

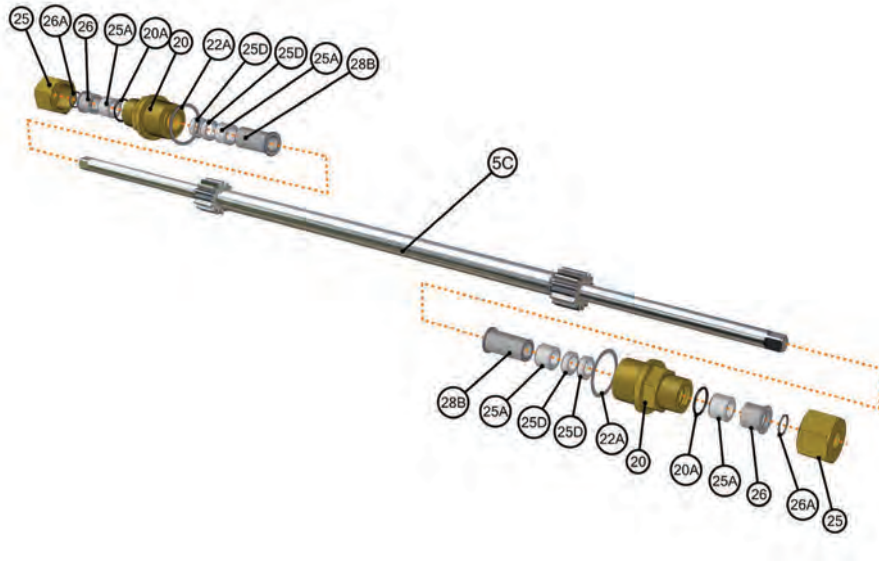

**90 - CLIPPER VALVE ASSEMBLY**

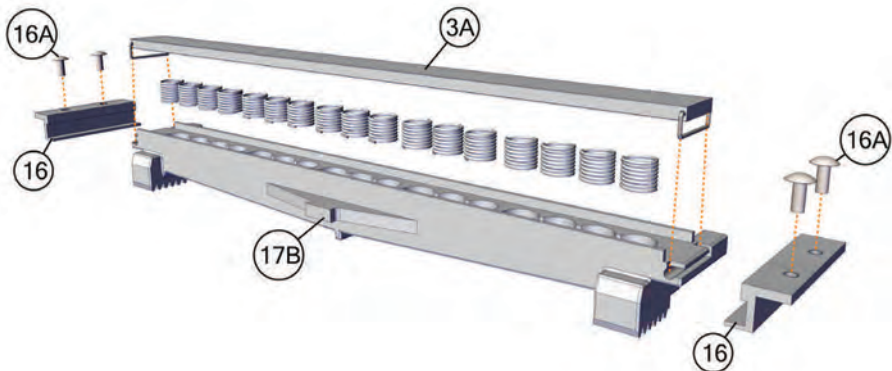

Part	Qty.	Description
01	1	Equalizer Valve Assembly
1G	1	Equalizer Valve Stem
1H	1	Equalizer Valve Packing Nut
1D	1	Equalizer Ball
1K	1	Equalizer Packing Washer
1J	1	Equalizer Packing
02	2	Operating Wrench
3A	1	Clip-Style Valve Strip
04	1	Flangeneck Body
4A	1	Body O-ring
5C	3	Dual Shaft & Pinion Gear
5A	2	Slide Valve Indicator Plate
5B	1	Slide Valve Indicator Pointer
08	1	Plate Carrier
8S	2	Plate Retaining Screw
8W	2	Plate retaining Washer
9G	1	Seal Bar with O-ring Groove
9B	1	Seal Bar O-ring
10H	1	Bleeder Valve
10P	1	Bleeder Valve Pipe Nipple
11	A/R	Clamping Bar Screw
12	1	Clamping Bar
** 13BH	1	Bonded "FLEX" Seal with Orifice Plate
14	1	Top Housing
15	A/R	Valve Spring
16	2	Valve Carrier Guide
16A	4	Valve Carrier Guide Screw
17A	2	Valve Carrier Stop Pin
17B	1	Valve Carrier
18A*/B	1	Valve Seat (Grease* /Soft)
18D	A/R	Valve Seat Screw

Part	Qty.	Description
18FH	1	Valve Seat Top O-ring
18GH*	2	Valve Seat Grease Port Seal
20	6	Stuffing Box
20A	6	Stuffing Box Outer Gland Seal
22A	6	Stuffing Box Gasket
* 23	1	Grease Gun Assembly
* 23A	1	Grease Gun Stem
* 23B	1	Grease Gun Body
24	1	Double Ball Grease Check Valve
25	6	Packing Nuts
25A-F	A/R	Packing Sleeve
25S2	1	Complete Packing Set
26	6	Stuffing Box Gland
26A	6	Stuffing Box Inner Gland Seal
28B	6	Bushing Retainer - Stuffing Box
30	2	Drain Plug
31	4	Meter Tap Plug (Qty = 8 with teletaps)
32	A/R	Hex Nuts
33	A/R	Body Studs
50	1	Specification Plate
52	1	Operating Instruction Plate
* 54	A/R	Slide Valve Lubricant
55	3	Eccentricity Alignment Pin
56	3	Eccentricity Alignment Pin Plug
58	1	Plate Carrier Alignment Screw
70	3	Gear Shaft Assemblies - See Detail
80	1	Valve Seat Assembly - See Detail
90	1	Clipper Valve Assembly - See Detail

A/R = As Required per Model Size

\* Not Applicable for Soft Seat design

\*\* Other types of orifice plate seals are available upon request

## 18" - 30" DUAL CHAMBER ORIFICE FITTINGS

### 90 - VALVE ASSEMBLY

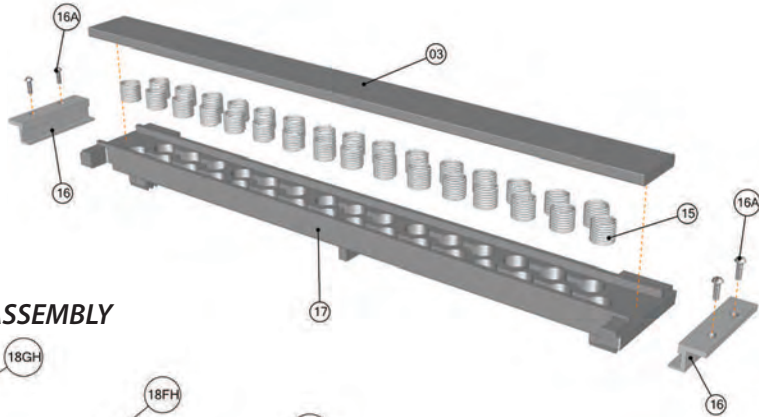

### 80 - VALVE SEAT ASSEMBLY

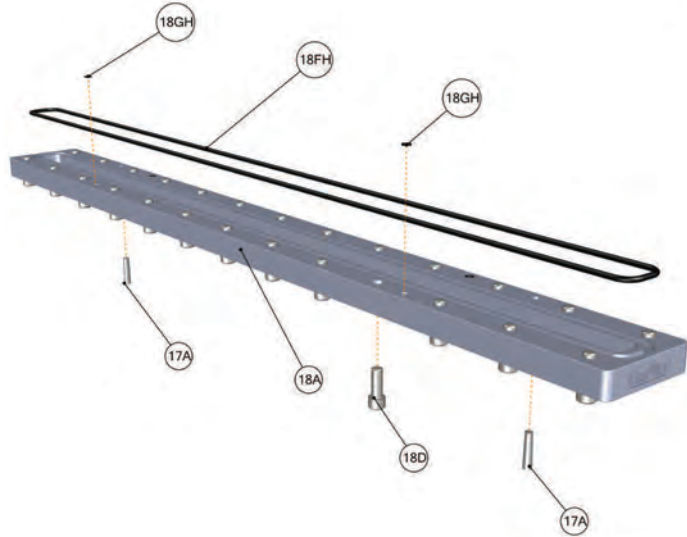

### 70 - GEAR SHAFT COMPONENTS

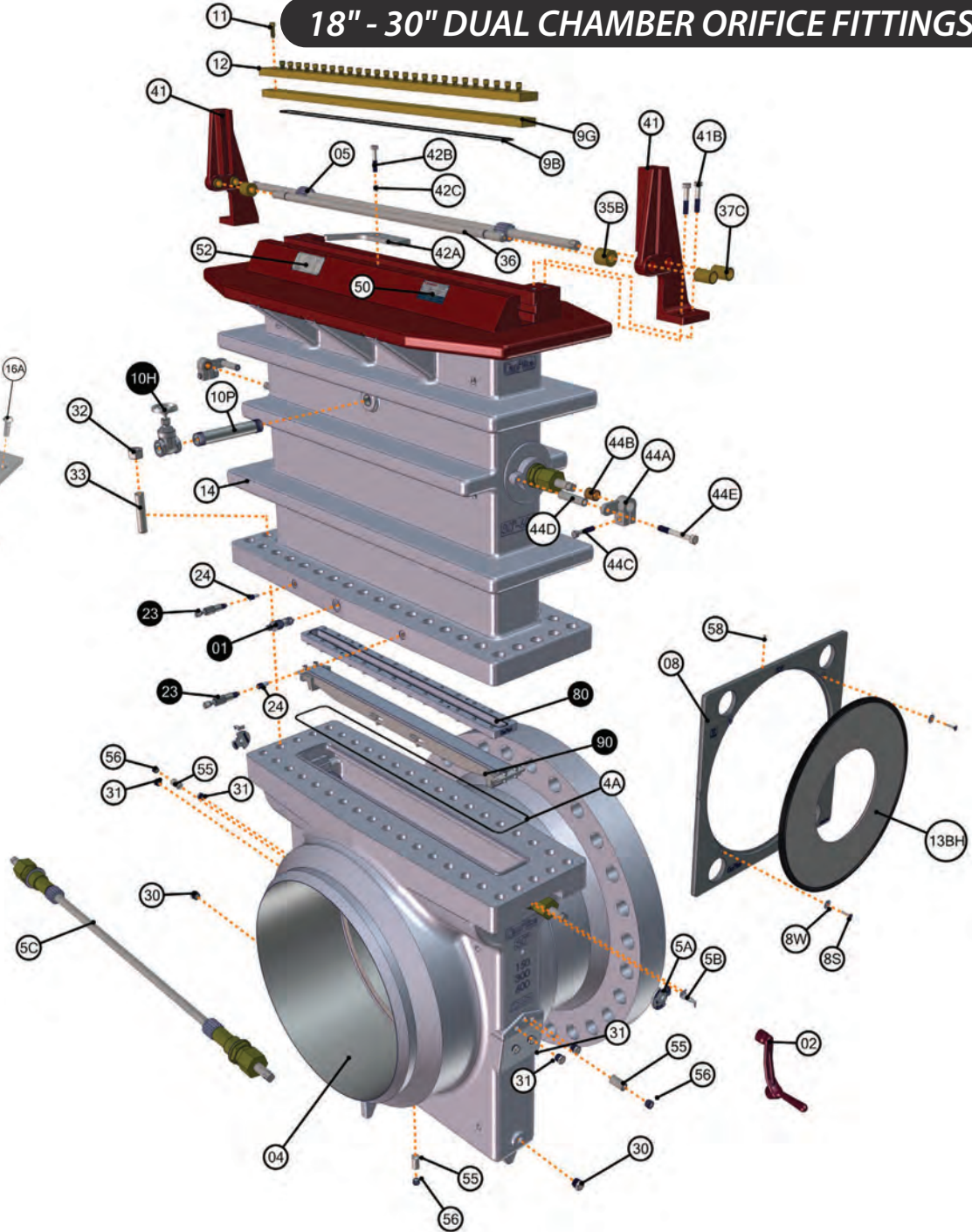
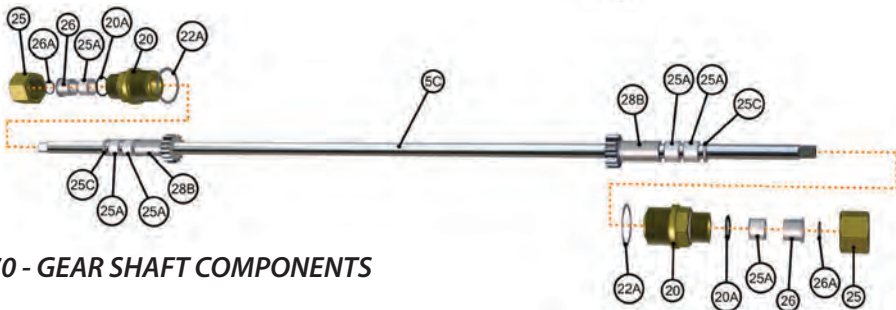

**01 - EQUALIZER ASSEMBLY**



**23 - GREASE GUN ASSEMBLY**  
(Used only on Grease Type Seat)



**44 - BRAKE ASSEMBLY**

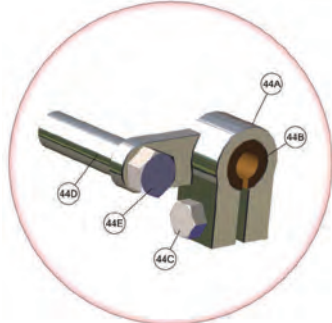

Part	Qty.	Description
01	1	Equalizer Valve Assembly
1G	1	Equalizer Valve Stem
1H	1	Equalizer Valve Packing Nut
1D	1	Equalizer Ball
1K	1	Equalizer Packing Washer
1J	1	Equalizer Packing
02	2	Operating Wrench
03	1	Valve Strip
04	1	Flangeneck Body
4A	1	Body O-ring
5C	4	Dual Shaft & Pinion Gear
5A	2	Slide Valve Indicator Plate
5B	2	Slide Valve Indicator Pointer
08	1	Plate Carrier
8S	2	Plate Retaining Screw
8W	2	Plate retaining Washer
9G	1	Seal Bar with O-ring Groove
9B	1	Seal Bar O-ring
10H	1	Bleeder Valve
10P	1	Bleeder Valve Pipe Nipple
11	A/R	Clamping Bar Screw
12	1	Clamping Bar
** 13BH	1	Bonded "FLEX" Seal with Orifice Plate
14	1	Top Housing
15	A/R	Valve Spring
16	2	Valve Carrier Guide
16A	4	Valve Carrier Guide Screw
17	1	Valve Carrier
17A	2	Valve Carrier Stop Pin

Part	Qty.	Description
18A*/B	1	Valve Seat (Grease* /Soft)
18D	A/R	Valve Seat Screw
18FH	1	Valve Seat Top O-ring
18GH*	2	Valve Seat Grease Port Seal
20	6	Stuffing Box
20A	6	Stuffing Box Outer Gland Seal
22A	6	Stuffing Box Gasket
* 23	2	Grease Gun Assembly
* 23A	2	Grease Gun Stem
* 23B	2	Grease Gun Body
24	2	Double Ball Grease Check Valve
25	6	Packing Nut
25A-F	A/R	Packing Sleeve
25S2	1	Complete Packing Set
26	6	Stuffing Box Glands
26A	6	Stuffing Box Inner Gland Seal
26B	6	Stuffing Box Outer Gland Seal
28B	6	Bushing Retainer - Stuffing Box
30	2	Drain Plug
31	4	Meter Tap Plugs (Qty = 8 with teletaps)
32	A/R	Hex Nuts
33	A/R	Body Stud
35B	2	External Shaft Roller
36	1	External Shaft
37C	4	Shaft Bushing
41B	4	Plate Carrier Guide Bolt
41L	1	Plate Carrier Guide Left
41R	1	Plate Carrier Guide Right
42A	1	Plate Carrier Stop

Part	Qty.	Description
42B	1	Plate Carrier Stop Bolt
42C	1	Plate Carrier Stop Bushing
44A	1	Travel Brake Body
44B	1	Brake Band
44C	1	Brake Adjustment Bolt
44D	1	Brake Sleeve
44E	1	Hex Head Bolt
50	1	Specification Plate
52	1	Operating Instruction Plate
* 54	A/R	Slide Valve Lubricant
55	3	Eccentricity Alignment Pin
56	3	Eccentricity Alignment Pin Plug
58	1	Plate Carrier Alignment Screw
70	3	Gear Shaft Assemblies - See Detail
80	1	Valve Seat Assembly - See Detail
90	1	Valve Assembly - See Detail

A/R = As Required per Model Size  
 \* Not Applicable for Soft Seat design  
 \*\* Other types of orifice plate seals are available upon request



## 2" - 14" DOUBLE BLOCK & BLEED ORIFICE FITTINGS

Note: Meter shown is Soft Seat design

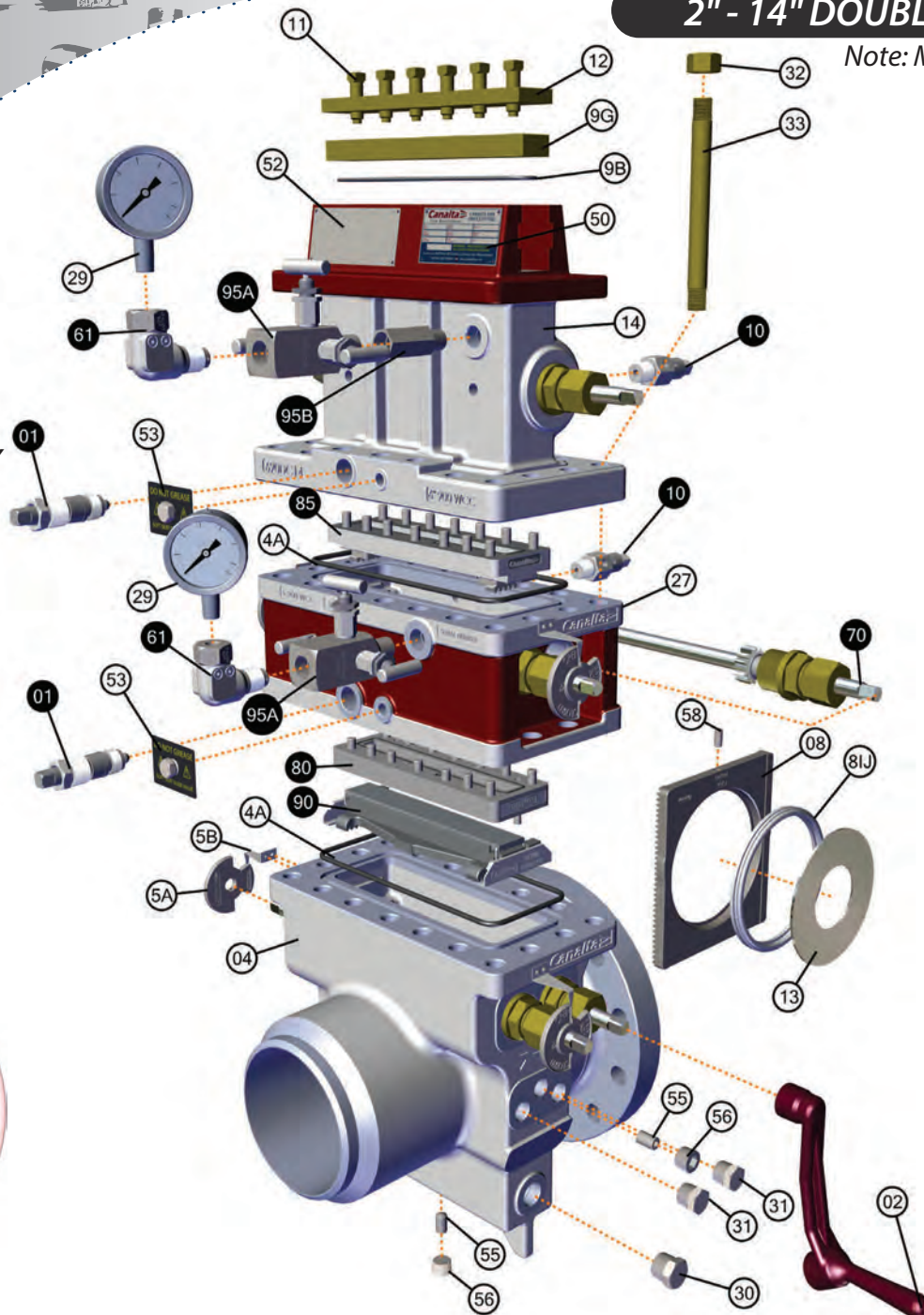

**23 - GREASE GUN ASSEMBLY**  
(Used only on Grease Type Seat)



**01 - EQUALIZER ASSEMBLY**



**85 - WEDGE VALVE SEAT ASSEMBLY**

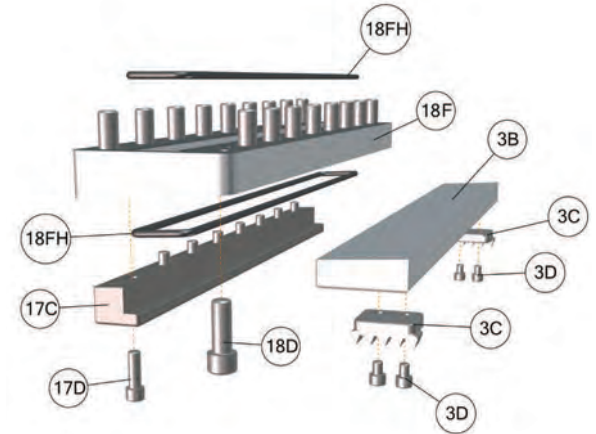

**80 - VALVE SEAT ASSEMBLY**

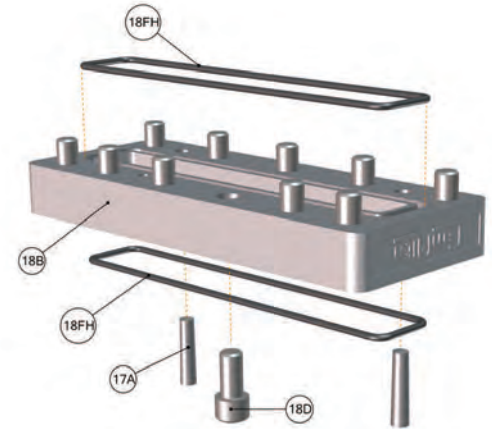

**90 - CLIPPER VALVE ASSEMBLY**

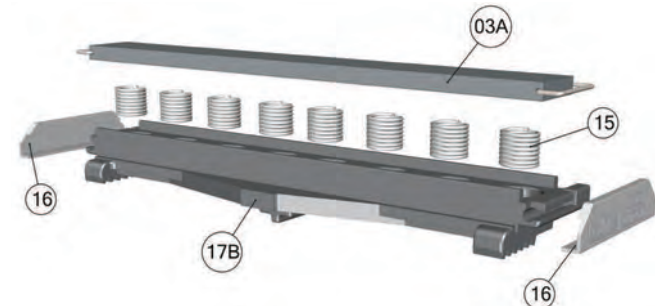

Part	Qty.	Description
01	2	Equalizer Valve Assembly
02	2	Operating Wrench
3A	1	Clip-Style Valve Strip
3B	1	Valve Strip (Wedge-style)
3C	2	Valve Strip Gear Plate
3D	4	Gear Plate Screw
04	1	Flangeneck Body
4A	2	Body O-ring
5A	A/R	Slide Valve Indicator Plate
5B	A/R	Slide Valve Indicator Pointer
5C	5	Dual Shaft & Pinion Gear

Part	Qty.	Description
08	1	Plate Carrier
** 8IJ	1	Teflon Orifice Plate Seal
9G	1	Seal Bar with O-ring Groove
9B	1	Seal Bar O-ring
10	2	Bleeder Valve
11	A/R	Clamping Bar Screw
12	1	Clamping Bar
13	1	Orifice Plate
14	1	Top Housing
15	A/R	Valve Springs
16	2	Valve Carrier Guide
17A	2	Valve Carrier Stop Pin
17B	1	Valve Carrier
17C	1	Valve Stop Plate
17D	A/R	Stop Plate Screw
18A*/B	1	Valve Seat (Grease*/Soft)
18D	A/R	Valve Seat Screws
18F	1	Wedge Style Valve Seat
18FH	2	Valve Seat Top O-ring
18GH*	2	Valve Seat Grease Port Seal
20	10	Stuffing Box
20A	10	Stuffing Box Outer Gland Seal
22A	10	Stuffing Box Gasket
* 23	2	Grease Gun Assembly
24	2	Double Ball Grease Check Valve
25	10	Packing Nut
25A-F	A/R	Packing Sleeve
25S2	A/R	Complete Packing Set

Part	Qty.	Description
26	10	Stuffing Box Glands
26A	10	Stuffing Box Inner Gland Seal
26B	A/R	Stuffing Box Inner Extension Seal
27	1	Mid Housing
29	2	Pressure Gauge
31	4	Meter Tap Plug (Qty = 8 with teletaps)
32	A/R	Hex Nuts
33	A/R	Body Studs
50	1	Specification Plate
52	1	Operating Instruction Plate
53	2	Soft Seat Warning Plate
* 54	A/R	Slide Valve Lubricant
55	3	Eccentricity Alignment Pin
56	3	Eccentricity Alignment Pin Plug
58	1	Plate Carrier Alignment Screw
61	2	Swivel Blow Out Preventor
65	A/R	Valve Lockout Assembly (not shown)
70	5	Gear Shaft Assemblies - See Detail
80	1	Valve Seat Assembly - See Detail
85	1	Wedge Valve Assembly - See Detail
90	1	Clipper Valve Assembly - See Detail
95A	2	DBB Needle Valve Assembly
95B	1	Threaded Adapter

A/R = As Required per Model Size or option

\* Not Applicable for Soft Seat design

\*\* Other types of orifice plate seals are available upon request

**70 - GEAR SHAFT COMPONENTS**

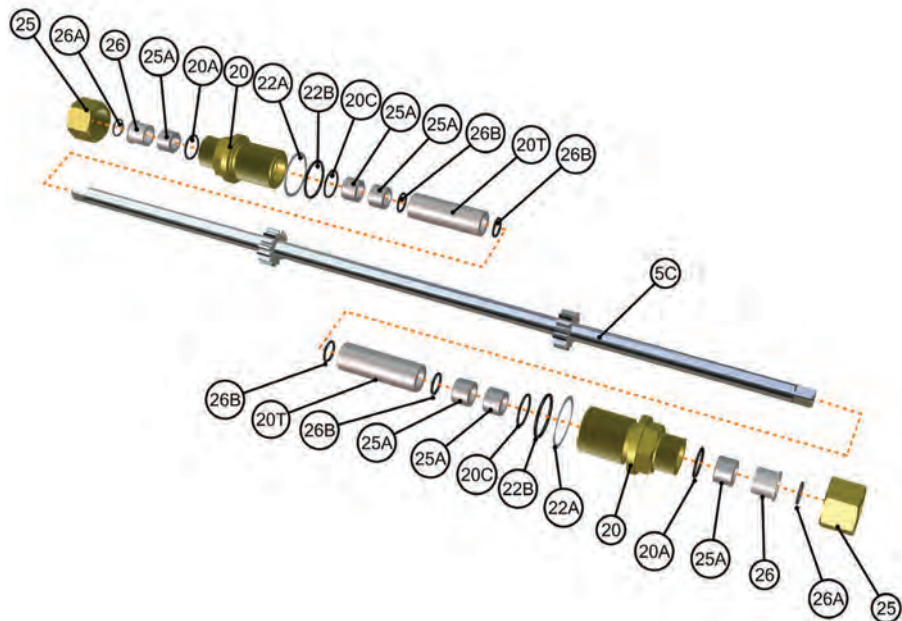



## 16" DOUBLE BLOCK & BLEED ORIFICE FITTINGS

Note: Meter shown is Grease Seat design

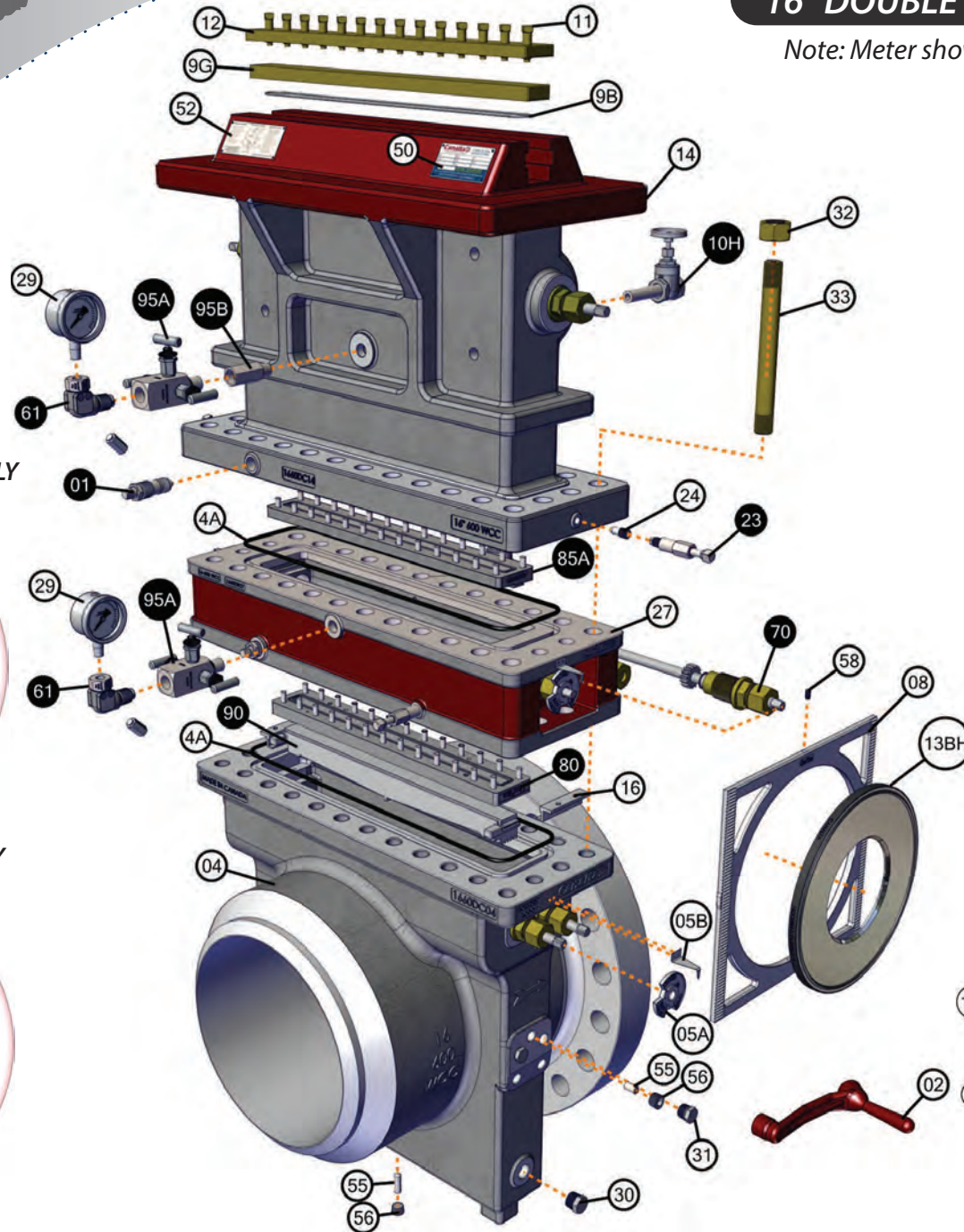

**23 - GREASE GUN ASSEMBLY**  
(Used only on Grease Type Seat)



**01 - EQUALIZER ASSEMBLY**



**85 - WEDGE VALVE SEAT ASSEMBLY**

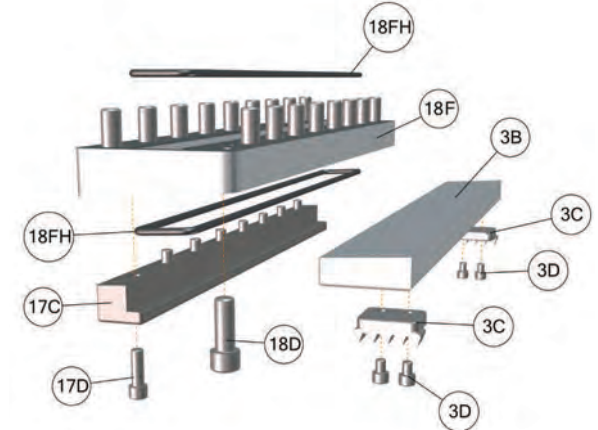

**80 - VALVE SEAT ASSEMBLY**

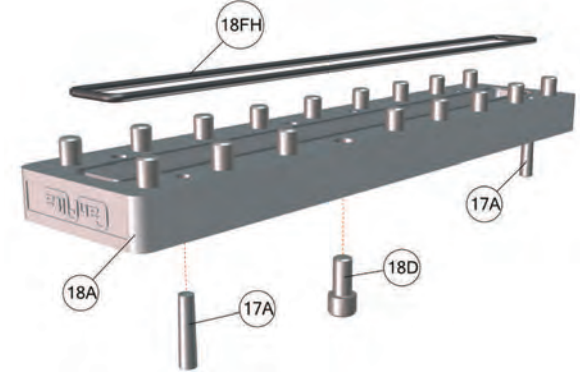

**90 - VALVE ASSEMBLY**

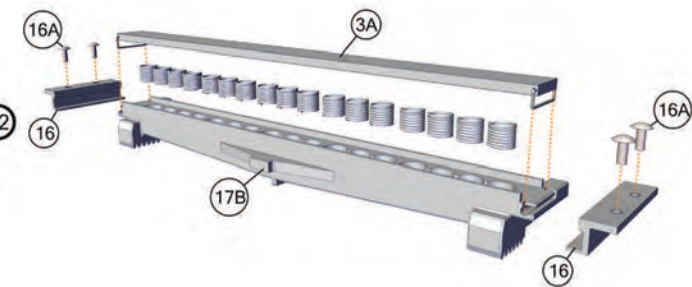



Part	Qty.	Description
01	2	Equalizer Valve Assembly
02	2	Operating Wrench
3A	1	Clip-Style Valve Strip
3B	1	Valve Strip (Wedge-style)
3C	2	Valve Strip Gear Plate
3D	4	Gear Plate Screw
04	1	Flangeneck Body
4A	2	Body O-ring
5A	A/R	Slide Valve Indicator Plate
5B	A/R	Slide Valve Indicator Pointer
5C	5	Shaft & Pinion Gear

Part	Qty.	Description
08	1	Plate Carrier
** 13BH	1	Bonded "FLEX" Seal with Orifice Plate
9G	1	Seal Bar with O-ring Groove
9B	1	Seal Bar O-ring
10H	2	Bleeder Valve
10P	2	Bleeder Valve Pipe Nipple
11	A/R	Clamping Bar Screw
12	1	Clamping Bar
14	1	Top Housing
15	A/R	Valve Spring
16	2	Valve Carrier Guide
17A	2	Valve Carrier Stop Pin
17B	1	Valve Carrier
17C	1	Valve Stop Plate
17D	A/R	Stop Plate Screw
18A*/B	1	Valve Seat (Grease* /Soft)
18D	A/R	Valve Seat Screw
18F	1	Wedge Style Valve Seat
18FH	A/R	Valve Seat Top O-ring
18GH*	A/R	Valve Seat Grease Port Seal
20	10	Stuffing Box
20A	10	Stuffing Box Outer Gland Seal
20T	10	Stuffing Box Extension
22A	10	Stuffing Box Gasket
* 23	A/R	Grease Gun Assembly
24	A/R	Double Ball Grease Check Valve
25	10	Packing Nut
25A-F	A/R	Packing Sleeve
25S2	A/R	Complete Packing Set

Part	Qty.	Description
26	10	Stuffing Box Gland
26A	10	Stuffing Box Inner Gland Seal
26B	A/R	Stuffing Box Inner Extension Seal
27	1	Mid Housing
28A	10	Bushing Retainer - Stuffing Box
29	2	Pressure Gauge
31	4	Meter Tap Plug (Qty = 8 with teletaps)
32	A/R	Hex Nut
33	A/R	Body Stud
50	1	Specification Plate
52	1	Operating Instruction Plate
53	1	Soft Seat Warning Plate
* 54	A/R	Slide Valve Lubricant
55	3	Eccentricity Alignment Pin
56	3	Eccentricity Alignment Pin Plug
58	1	Plate Carrier Alignment Screw
61	2	Swivel Blow Out Preventor
65	1	Valve Lockout Assembly (not shown)
70	5	Gear Shaft Assemblies - See Detail
80	1	Valve Seat Assembly - See Detail
85	1	Wedge Valve Assembly - See Detail
90	1	Clipper Valve Carrier Assembly - See Detail
95A	2	DBB Needle Valve Assembly
95B	A/R	Threaded Adapter

A/R = As Required per Model Size or option  
 \* Not Applicable for Soft Seat design  
 \*\* Other types of orifice plate seals are available upon request

**70 - GEAR SHAFT COMPONENTS**

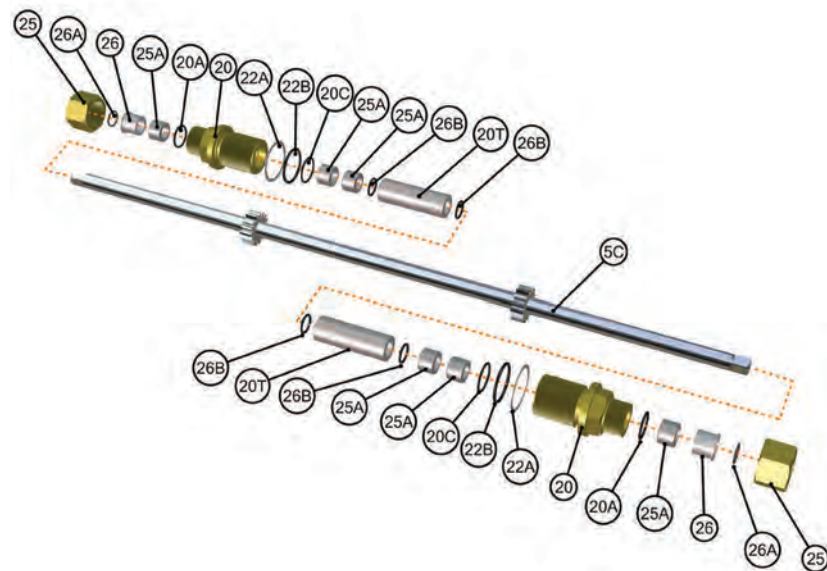

## 18" - 30" DOUBLE BLOCK & BLEED ORIFICE FITTINGS

85 - WEDGE VALVE SEAT ASSEMBLY

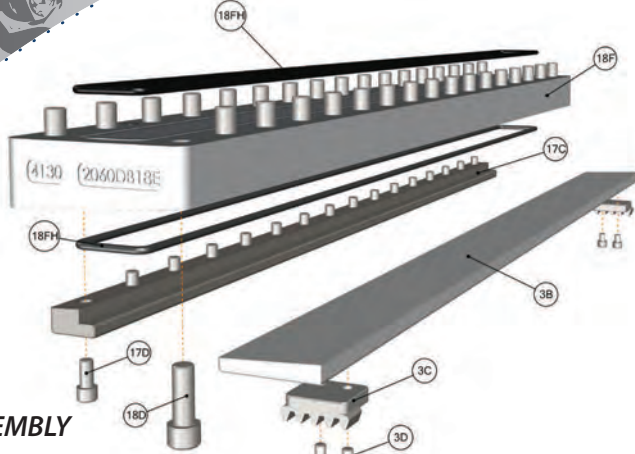

80 - VALVE SEAT ASSEMBLY

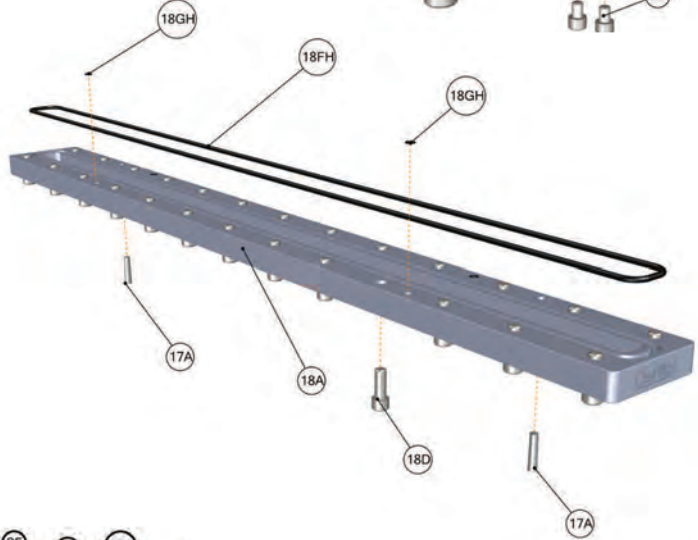

01 - EQUALIZER ASSEMBLY



70 - GEAR SHAFT COMPONENTS

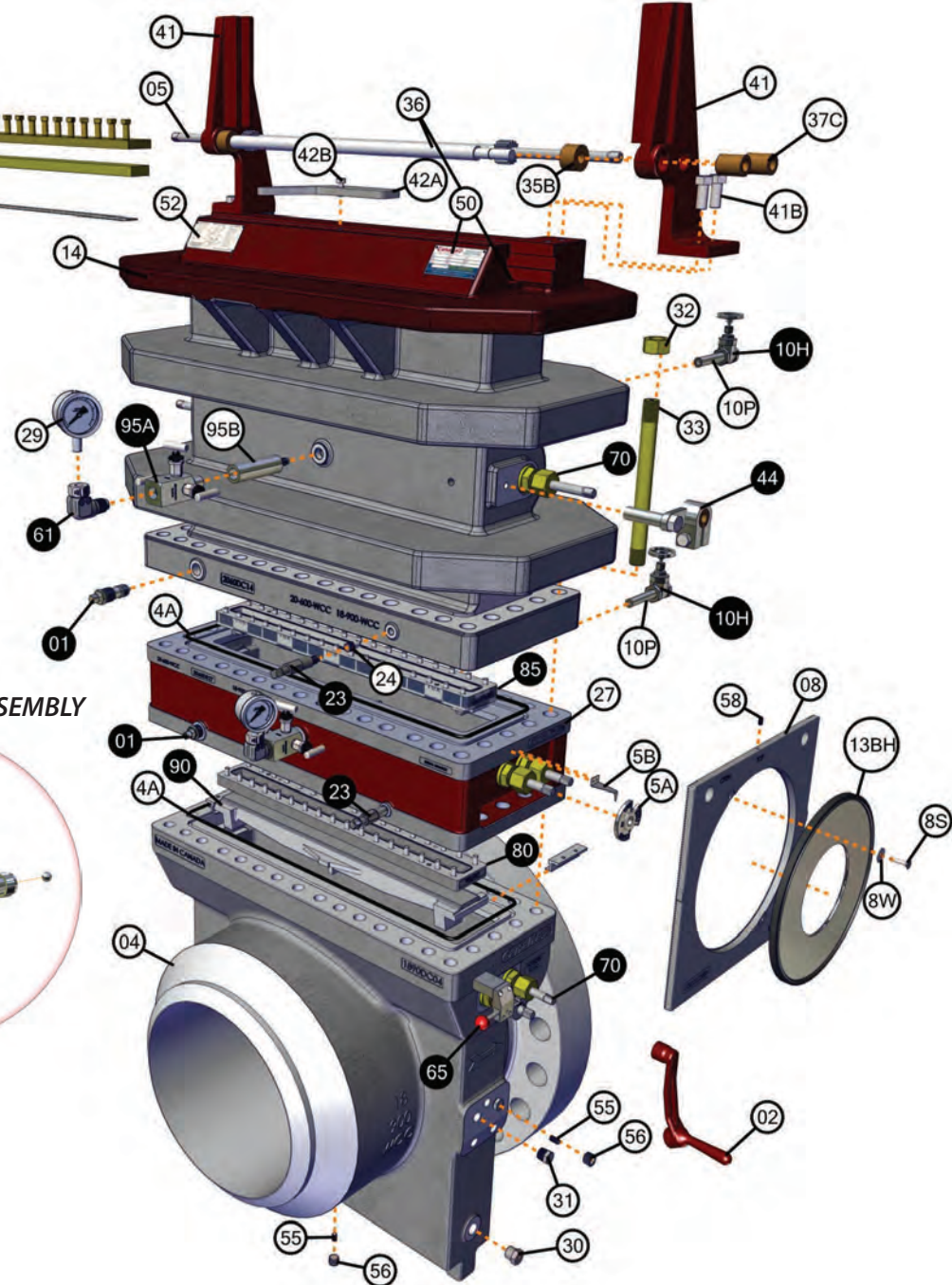
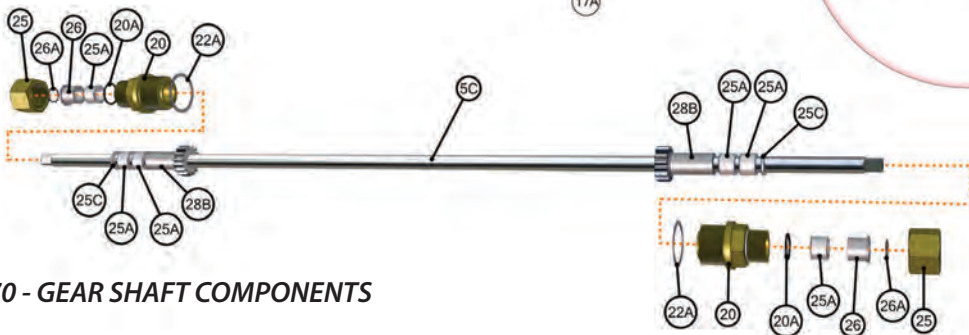

**23 - GREASE GUN ASSEMBLY**  
(Used only on Grease Type Seat)



**44 - BRAKE ASSEMBLY**

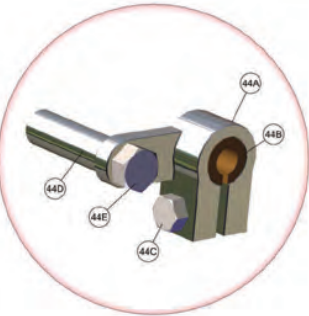

**90 - VALVE ASSEMBLY**

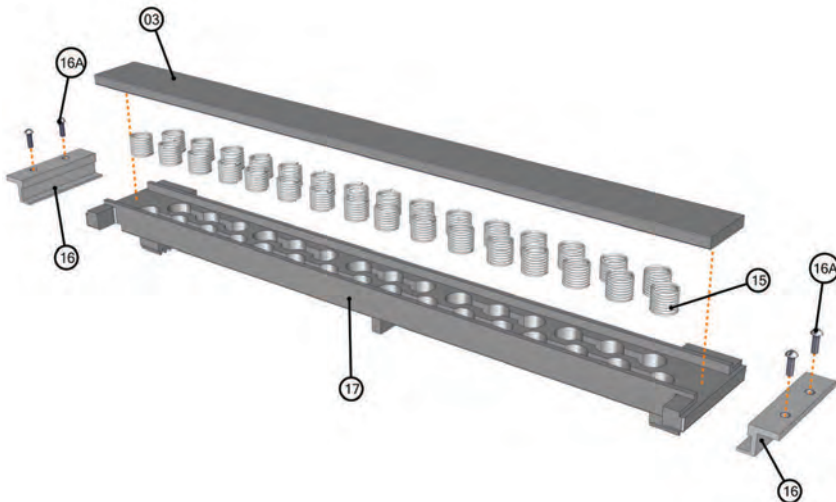

Part	Qty.	Description	Part	Qty.	Description	Part	Qty.	Description
01	2	Equalizer Valve Assembly	**13BH	1	Bonded "FLEX" Seal with Orifice Plate	33	A/R	Body Stud
02	2	Operating Wrench	14	1	Top Housing	35B	2	External Shaft Roller
03	1	Valve Strip	15	A/R	Valve Spring	36	1	External Shaft
3B	1	Wedge Style Valve Strip	16	2	Valve Carrier Guide	37C	4	Shaft Bushing
3C	2	Valve Strip Gear Plate	16A	4	Valve Carrier Guide Screw	41B	4	Plate Carrier Guide Bolt
3D	4	Gear Plate Screw	17	1	Valve Carrier	41L	1	Plate Carrier Guide Left
04	1	Flangeneck Body	17A	2	Valve Carrier Stop Pin	41R	1	Plate Carrier Guide Right
4A	2	Body O-ring	17C	1	Valve Stop Plate	42A	1	Plate Carrier Stop
5C	6	Dual Shaft & Pinion Gear	17D	A/R	Stop Plate Screw	42B	1	Plate Carrier Stop Bolt
5A	2	Slide Valve Indicator Plate	18A*/B	1	Valve Seat (Grease* /Soft)	42C	1	Plate Carrier Stop Bushing (not shown)
5B	2	Slide Valve Indicator Pointer	18D	A/R	Valve Seat Screw	44	1	Travel Brake Assembly
08	1	Plate Carrier	18F	1	Wedge Style Valve Seat	44A	1	Travel Brake Body
8W	2	Plate Carrier Retaining Screw	18FH	A/R	Valve Seat Top O-ring	44B	1	Brake Band
8W	2	Plate Carrier Retaining Washer	18GH*	A/R	Valve Seat Grease Port Seal	44C	1	Brake Adjustment Bolt
9G	1	Seal Bar with O-ring Groove	20	10	Stuffing Box	44D	1	Brake Sleeve
9B	1	Seal Bar O-ring	20A	10	Stuffing Box Outer Gland Seal	44E	1	Hex Head Bolt
10H	2	Bleeder Valve	20T	10	Stuffing Box Extension	50	1	Specification Plate
10P	2	Bleeder Valve Pipe Nipple	22A	10	Stuffing Box Gasket	52	1	Operating Instruction Plate
11	A/R	Clamping Bar Screw	* 23	A/R	Grease Gun Assembly	* 54	A/R	Slide Valve Lubricant
12	1	Clamping Bar	* 23A	A/R	Grease Gun Stem	55	3	Eccentricity Alignment Pin
			* 23B	A/R	Grease Gun Body	56	3	Eccentricity Alignment Pin Plug
			24	A/R	Double Ball Grease Check Valve	58	1	Plate Carrier Alignment Screw
			25	10	Packing Nut	61	2	Swivel Blow Out Preventor
			25A-F	A/R	Packing Sleeve	65	1	Valve Lockout Assembly
			25S2	1	Complete Packing Set	70	3	Gear Shaft Assemblies - See Detail
			26	6	Stuffing Box Glands	80	1	Valve Seat Assembly - See Detail
			26A	6	Stuffing Box Inner Gland Seal	85	1	Wedge Valve Seat Assembly - See Detail
			26	6	Stuffing Box Outer Gland Seal	90	1	Valve Assembly - See Detail
			28B	6	Bushing Retainer - Stuffing Box	95A	2	DBB Needle Valve Assembly
			30	2	Drain Plug	95B	A/R	Threaded Adapter
			31	4	Meter Tap Plugs (Qty = 8 with teletaps)			
			32	A/R	Hex Nut			

A/R = As Required per Model Size or option

\* Not Applicable for Soft Seat design

\*\* Other types of orifice plate seals are available upon request



**Canalta** 

*Flow Measurement*

An ISO 9001:2015 Registered Company

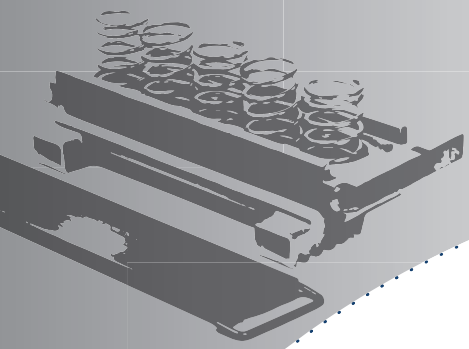

***SPARE PARTS FOR ALL  
8"+ SINGLE CHAMBER,  
DUAL CHAMBER &  
DBB ORIFICE FITTINGS***

## CANALTA REPAIR KITS

### CANALTA ORIFICE FITTING REPAIR KITS

include a full complement of orifice fitting parts, allowing for a complete rebuild of the orifice fitting or replenishment of spare parts inventory. These kits are available with 316 stainless steel internals for standard applications or Duplex and Super Duplex internals for extreme corrosive applications. All repair kits include high grade HNBR internal seals and are packaged in a sturdy resin case for easy storage or transport.

Repair kits for Daniel® Senior® Orifice Fittings are equally comprehensive. These parts can also be supplied on an individual basis. Please contact us for full details on our servicing of Daniel product lines.

*Trust Canalta Flow Measurement for high quality, competitively priced OEM and interchangeable orifice fitting*





## FULL REPAIR KITS

The repair kit part numbers are in the following format:  
 KIT - KIT TYPE - SIZE - ANSI CLASS - SEAL GAP - TRIM - VALVE SEAT

KIT TYPE - 'C' (2000 Edition), 'D' (85 Edition), 'DN' (Daniels Notched)  
 ANSI CLASS - 90 (150-900 ANSI), 150 (1500 ANSI) & 250 (2500 ANSI)  
 METER TYPE - SC (Single Chamber), DC (Dual Chamber), & DBB (Double Block & Bleed)  
 SEAL GAP - 562 (0.562 - 2"-6"), 688 (0.688 - 8"-14"), 813 (0.813 - 16"-20") & 875 (0.875 - 24"-30")  
 TRIM - SS (Corrosive Stainless Steel) & FSS (Full Stainless Steel). Other materials are available upon request.  
 VALVE SEAT - 'G' (Grease seat), 'S' (Soft Seat)  
 GEARS - '2' (Dual Shaft)

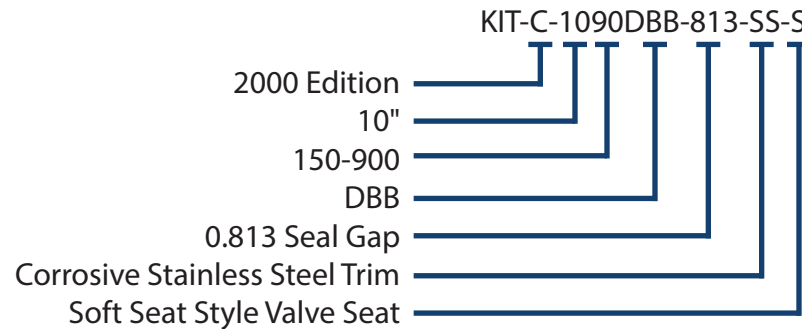
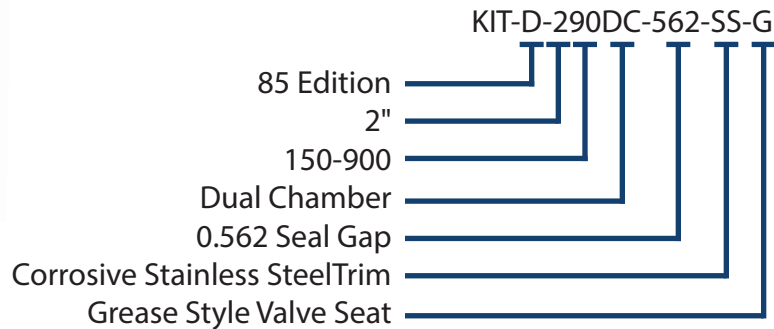

Canalta can also provide Commissioning Kits and Spares Kits for all of the meters. These kit part numbers are based on the same format as above, replacing the KIT TYPE with either 'COM' (Commissioning Kit) or 'SP' (2 years full maintenance kit for strip down and rebuild).

**Commissioning Kits:** Designed with replacement pieces that could potentially be damaged during transportation (IE: A gear assembly) and a set of replacement O-Rings. Intended for sale alongside new fitting orders.

**2 Year Spare Parts Kits:** Designed to include one change-out of the internal parts, two change-outs of the O-Rings, and only partial bolt up as these are seldom required to change out entirely. Intended for sale alongside new fitting orders.

## DBB, DUAL CHAMBER / 8"+ SINGLE CHAMBER FITTING PARTS

### #8 Plate Carrier



Downstream Face View

Upstream Face View

Available in CF8M cast stainless steel as standard.

*If 85 Edition parts are required, replace "92-SS" with "85-SS" (applicable for Standard non-notched only)*

#### CF8M Stainless Steel

Model Size	Part Number (Standard non-notched)	Part Number (Standard Notched)	Notes
2	260DC08-92-SS	260DC08SN-92-SS	
3	360DC08-92-SS	360DC08SN-92-SS	
4	460DC08-92-SS	460DC08SN-92-SS	
6	660DC08-92-SS	660DC08SN-92-SS	
8 *	860DC08-00-625-SS	860DC08SN-92-SS	
10 *	1060DC08-SS		
12 *	1260DC08-SS		
14 *	1460DC08-SS		
16 *	1660DC08-SS		
18 *	1860DC08-SS		
20 *	2060DC08-SS		
24 *	2460DC08-SS		
26 *	2660DC08-SS		
30 *	3060DC08-SS		

### #5 Shaft & Pinion Gears

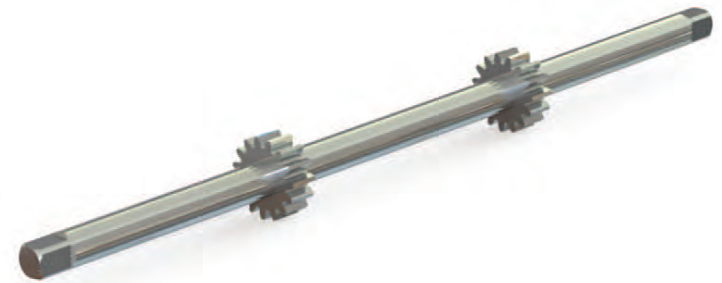

Available in stainless steel.

Shafts for all model sizes are of the dual wrench design.

#### CF8M Stainless Steel

	150-1500 ANSI	2500 ANSI	
Model Size	Part Number	Part Number	Notes
2	260DC05C-SS	260DC05C-SS	
3	360DC05C-SS	3250DC05C-SS	
4	460DC05C-SS	4250DC05C-SS	
6	660DC05C-SS	<b>6250DC05C-SS</b>	
8 *	860DC05C-SS	8250DC05C-SS	
10 *	1060DC05C-SS	10250DC05C-SS	
12 *	1260DC05C-SS	12250DC05C-SS	
14 *	1460DC05C-SS	14250DC05C-SS	
16 *	1660DC05C-SS	16250DC05C-SS	
18 *	2060DC05C-SS	20250DC05C-SS	
20 *	2060DC05C-SS	20250DC05C-SS	
24 *	2460DC05C-SS	24250DC05C-SS	
26 *	2660DC05C-SS	26250DC05C-SS	
30 *	3060DC05C-SS	30250DC05C-SS	

\* Indicates parts also applicable to 8" and larger model sizes of the Single Chamber Orifice Fitting.

**VARIABLE BY MODEL SIZE**

**#90 Clip Style Valves Assembly**



Available as standard in CF8M cast stainless steel.

	150-1500 ANSI	2500 ANSI	
Model Size	Part Number	Part Number	Notes
2	2150DC90-SS	2250DC90-SS	
3	3150DC90-SS	3250DC90-SS	
4	4150DC90-SS	4250DC90-SS	
6	6150DC90-SS	6250DC90-SS	
8	8150DC90-SS	8250DC90-SS	
10	10150DC90-SS	10250DC90-SS	
12	12150DC90-SS	12250DC90-SS	
14	14150DC90-SS		
16	1690DC90-SS		

Notes: Clipper assembly available up to and including 16".  
Other materials available upon request

**#3 Valve Strip**



A564 Gr.630 Stainless Steel			
	150-1500 ANSI	2500 ANSI	
Model Size	Part Number	Part Number	Notes
2	260DC03A	2250DC03A	
3	360DC03A	3250DC03A	
4	460DC03A	4250DC03A	
6	660DC03A	6250DC03A	
8	860DC03A	8250DC03A	
10	1060DC03A	10250DC03A	
12	1260DC03A	12250DC03A	
14	1460DC03A		
16	1660DC03A		
18	2060DC03		
20	2060DC03		
24	2460DC03		
26	2660DC03		
30	3060DC03		

Note: 'A' suffix denotes clipper compatible component

**#17 Valve Carrier**



CF8M Stainless Steel		
Model Size	Part Number	Notes
2	260DC17B-SS	
3	360DC17B-SS	
4	460DC17B-SS	
6	660DC17B-SS	
8	860DC17B-SS	
10	1060DC17B-SS	
12	1260DC17B-SS	
14	1460DC17B-SS	
16	1660DC17B-SS	
18	2060DC17-SS	
20	2060DC17-SS	
24	2460DC17-SS	
26	2660DC17-SS	
30	3060DC17-SS	

Note: 'B' suffix denotes clipper compatible component



## DBB, DUAL CHAMBER / 8"+ SINGLE CHAMBER FITTING PARTS

**#9G Seal Bar**

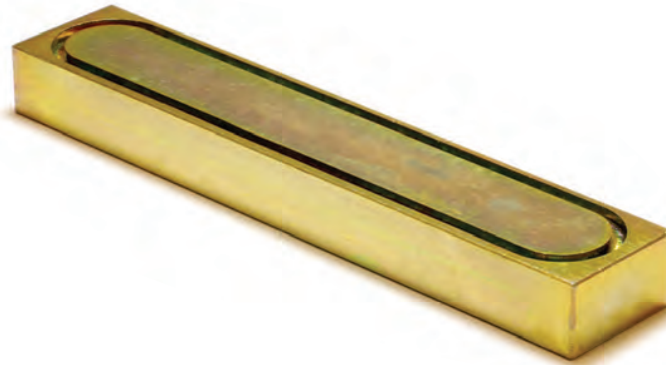

Available for 150 - 900, 1500 & 2500 ANSI ratings in 1018 YZP carbon steel.  
Requires one seal bar O-ring (#9B).

150 - 900 ANSI		1500 ANSI	2500 ANSI	
Model Size	Part Number	Part Number	Part Number	Notes
2	260DC09G	2250DC09G	2250DC09G	
3	360DC09G	3150DC09G	3250DC09G	
4	460DC09G	4150DC09G	4250DC09G	
6	660DC09G	6150DC09G	6250DC09G	
8 *	860DC09G	8250DC09G	8250DC09G	
10 *	1060DC09G	10150DC09G	10250DC09G	
12 *	1260DC09G	12250DC09G	12250DC09G	
14 *	1460DC09G	14150DC09G		
16 *	1660DC09G	16150DC09G		
18 *	2060DC09G	Please Call		
20 *	2060DC09G	Please Call		
24 *	2460DC09G	Please Call		
26 *	2660DC09G			
30 *	3060DC09G			

**#12 Clamping Bar**

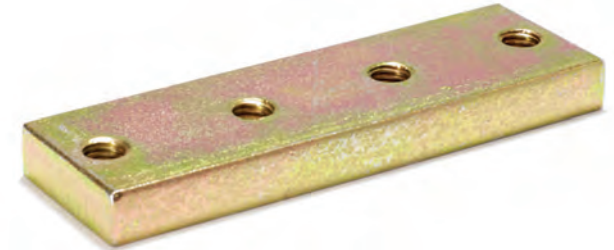

Available for 150 - 900, 1500 & 2500 ANSI ratings in 1018 YZP carbon steel.  
Requires corresponding clamping bar screws (#11).

150 - 900 ANSI		1500/2500 ANSI	
Model Size	Part Number	Part Number	Notes
2	260DC12	2250DC12	
3	360DC12	3250DC12	
4	460DC12	4250DC12	
6	660DC12	6250DC12	
8 *	860DC12	8250DC12	
10 *	1060DC12	10250DC12	
12 *	1260DC12	12250DC12	
14 *	1460DC12	14250DC12	
16 *	1660DC12	16250DC12	
18 *	2060DC12	Please Call	
20 *	2060DC12	Please Call	
24 *	2460DC12	Please Call	
26 *	2660DC12		
30 *	3060DC12		

YZP = Yellow Zinc Plated  
Other materials available upon request

★ Indicates parts also applicable to 8" and larger model sizes of the Single Chamber Orifice Fitting.

**VARIABLE BY MODEL SIZE**

**#18A Valve Seat - Grease Style**



Available in 316/316L stainless steel. This unit incorporates a machined grease port for slide valve lubrication. Requires one valve seat O-ring (#18FH), valve seat grease port seal(s) (#18GH) and slide valve lubricant (#54). Suitable for 150 - 900, 1500 & 2500 ANSI ratings.

	150-900 ANSI	1500 ANSI	2500 ANSI	
Model Size	Part Number	Part Number	Part Number	Notes
2	260DC18A-SS	260DC18A-SS	2250DC18A-SS	
3	360DC18A-SS	360DC18A-SS	3250DC18A-SS	
* 4	460DC18A-SS	4150DC18A-SS	4250DC18A-SS	
6	660DC18A-SS	660DC18A-SS	6250DC18A-SS	
8	860DC18A-SS	860DC18A-SS	8250DC18A-SS	
10	1060DC18A-SS	1060DC18A-SS	10250DC18A-SS	
12	1260DC18A-SS	1260DC18A-SS	12250DC18A-SS	
14	1460DC18A-SS	1460DC18A-SS		
* 16	1660DC18A-SS	16150DC18A-SS		
18	2060DC18A-SS	2060DC18A-SS		
20	2060DC18A-SS	2060DC18A-SS		
24	2460DC18A-SS	2460DC18A-SS		
26	2660DC18A-SS			
30	3060DC18A-SS			

\* Note: 4" 1500 & 16 1500 ANSI models require a specially-sized valve seat.

**#18B Valve Seat - Soft Seat Style**



Available in 316/316L stainless steel. This unit incorporates a specially machined seal channel to help prevent O-ring dislocation. Requires two valve seat O-rings (#18FH). Suitable for 150 - 900, 1500 & 2500 ANSI ratings.

	150-900 ANSI	1500 ANSI	2500 ANSI	
Model Size	Part Number	Part Number	Part Number	Notes
2	260DC18B-SS	260DC18B-SS	2250DC18B-SS	
3	360DC18B-SS	360DC18B-SS	3250DC18B-SS	
* 4	460DC18B-SS	4150DC18B-SS	4250DC18B-SS	
6	660DC18B-SS	660DC18B-SS	6250DC18B-SS	
8	860DC18B-SS	860DC18B-SS	8250DC18B-SS	
10	1060DC18B-SS	1060DC18B-SS	10250DC18B-SS	
12	1260DC18B-SS	1260DC18B-SS	12250DC18B-SS	
14	1460DC18B-SS	1460DC18B-SS		
* 16	1660DC18B-SS	16150DC18B-SS		
18	2060DC18B-SS	2060DC18B-SS		
20	2060DC18B-SS	2060DC18B-SS		
24	2460DC18B-SS	2460DC18B-SS		
26	2660DC18B-SS			
30	3060DC18B-SS			

\* Note: 4" 1500 & 16 1500 ANSI models require a specially-sized valve seat.

## DBB, DUAL CHAMBER / 8" + 6" SINGLE CHAMBER FORTINCE PARTINGS

### #3B Wedge Style Valve Strip



Available for 150-1500 & 2500 ANSI ratings in 316 SS.  
(2500 ANSI available only up to 12")  
Other materials available upon request.

150-1500 ANSI		2500 ANSI	
Model Size	Part Number	Part Number	Notes
2	290DB03B	2250DB03B	
3	390DB03B	3250DB03B	
4	490DB03B	4250DB03B	
6	690DB03B	6250DB03B	
8	890DB03B	8250DB03B	
10	1090DB03B	10250DB03B	
12	1290DB03B	12250DB03B	
14	1490DB03B		
16	1690DB03B		
18	2090DB03B		
20	2090DB03B		
24	2490DB03B		
26	2690DB03B		
30	3090DB03B		

**Note:** Fitted to DBB models only  
Other materials available upon request

### #17C Valve Stop Plate

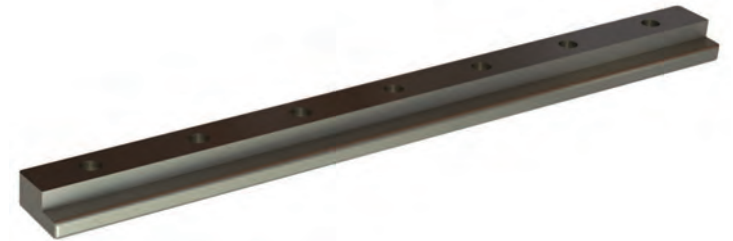

Available for 150-1500 & 2500 ANSI ratings in 316 SS.

150-1500 ANSI		2500 ANSI	
Model Size	Part Number	Part Number	Notes
2	290DB17C-SS	2250DB17C-SS	
3	390DB17C-SS	3250DB17C-SS	
4	490DB17C-SS	4250DB17C-SS	
6	690DB17C-SS	6250DB17C-SS	
8	890DB17C-SS	8250DB17C-SS	
10	1090DB17C-SS	10250DB17C-SS	
12	1290DB17C-SS	12250DB17C-SS	
14	1490DB17C-SS		
16	1690DB17C-SS		
18	2060DB17C-SS		
20	2060DB17C-SS		
24	2460DB17C-SS		
26	2660DB17C-SS		
30	3060DB17C-SS		

**Note:** Fitted to DBB models only  
Other materials available upon request



VARIABLE BY MODEL SIZE

#18F Wedge Style Valve Seat

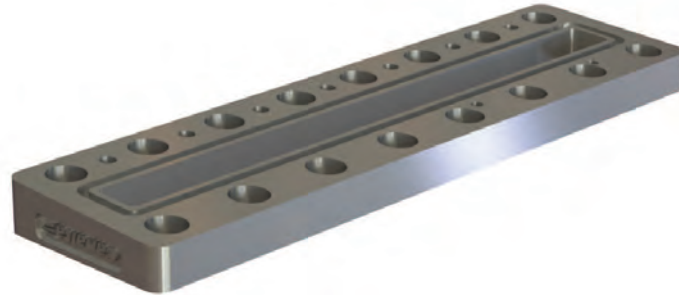

Available in 316/316L stainless steel. This unit incorporates a specially machined seal channel to help prevent O-ring dislocation. Requires two valve seat O-rings (#18FH). Suitable for 150-900, 1500 & 2500 ANSI ratings.

150-900 ANSI		1500 ANSI	2500 ANSI	
Model Size	Part Number	Part Number	Part Number	Notes
2	290DB18F-SS	2150DB18F-SS	2250DB18F-SS	
3	390DB18F-SS	3150DB18F-SS	3250DB18F-SS	
4	490DB18F-SS	4150DB18F-SS	4250DB18F-SS	
6	690DB18F-SS	6150DB18F-SS	6250DB18F-SS	
8	890DB18F-SS	8150DB18F-SS	8250DB18F-SS	
10	1090DB18F-SS	10150DB18F-SS	10250DB18F-SS	
12	1290DB18F-SS	12150DB18F-SS	12250DB18F-SS	
14	1490DB18F-SS	14150DB18F-SS		
16	1690DB18F-SS	16150DB18F-SS		
18	1890DB18F-SS	18150DB18F-SS		
20	2090DB18F-SS	20150DB18F-SS		
24	2490DB18F-SS	24150DB18F-SS		
26	2690DB18F-SS			
30	3090DB18F-SS			

**Note:** Fitted to DBB models only. DBB is offered as soft seat only on the upper slide

## DBB, DUAL CHAMBER / 8"+ SINGLE CHAMBER FITTING PARTS

### #18FH Valve Seat O-ring



HNBR Rubber

150-2500 ANSI		
Model Size	Part Number	Notes
2	O236-80H	
3	O243-80H	
4	O248-80H	
6	O258-80H	
8	O263-80H	
10	O268-80H	
12	O273-80H	
14	O277-80H	
16	O279-80H	
18	O282-80H	
20	O282-80H	
24	O387-80H	
26	O390-80H	
30	O392-80H	

### #9B Seal Bar O-ring



HNBR Rubber

150 - 900 ANSI		1500 ANSI	2500 ANSI
Model Size	Part Number	Part Number	Part Number
2	O238-80H	O345-80H	O345-80H
3	O247-80H	O427-80H	O348-80H
4	O250-80H	O434-80H	O353-80H
6	O261-80H	O443-80H	O437-80H
8 *	O265-80H	O445-80H	O445-80H
10 *	O269-80H	O374-80H	O373-80H
12 *	O275-80H	O378-80H	O378-80H
14 *	O277-80H	Please Call	
16 *	O280-80H	O456-80H	
18 *	O283-80H	Please Call	
20 *	O283-80H	Please Call	
24 *	O388-80H	Please Call	
26 *	O391-80H		
30 *	O392-80H		

### #4A Body O-ring



HNBR Rubber

	150-900 ANSI	1500 ANSI	2500 ANSI
Model Size	Part Number	Part Number	Part Number
2	O257-80H	O362-80H	O362-80H
3	O365-80H	O364-80H	O365-80H
4	O367-80H	O370-80H	O368-80H
6	O373-80H	O449-80H	O371-80H
8	O378-80H	O453-80H	O377-80H
10	O380-80H	O380-80H	O380-80H
12	O456-80H	O456-80H	O381-80H
14	O460-80H	Please Call	
16	O465-80H	O466-80H	
18	O471-80H	Please Call	
20	O471-80H	Please Call	
24	O473-80H	Please Call	
26	O475-80H		
30	O4ID27-80H		

**Note:** These part numbers also apply for item 18EH, "Valve Seat Bottom O-ring" for soft seat orifice fitting models.

★ Indicates parts also applicable to 8" and larger model sizes of the Single Chamber Orifice Fitting.

**VARIABLE BY MODEL SIZE**

**#32 Hex Head Nuts**



**A194 Gr.2HM YZP CS - alloy bolting.**  
Other materials available upon request.

	150-900 ANSI	1500 ANSI	2500 ANSI
Model Size	Part Number		
2	DC32N58	DC32N34	DC32N1
3	DC32N58	DC32N34	DC32N1
4	DC32N58	DC32N34	DC32N118
6	DC32N34	DC32N1	DC32N114
8	DC32N34	DC32N118	DC32N114
10	DC32N34	DC32N118	DC32N114
12	DC32N34	DC32N118	DC32N114
14	DC32N34	Please Call	
16	DC32N1	Please Call	
18	DC32N1	Please Call	
20	DC32N1	Please Call	
24	DC32N1	Please Call	
26	Please Call		
30	DC32N118		

YZP = Yellow Zinc Plated

**#33 Body Studs (Dual Chamber Meters Only)**



**A193 YZP CS - B7M alloy bolting.** Other materials available upon request.

	Short Studs			Long Studs		
	150-900 ANSI	1500 ANSI	2500 ANSI	150-900 ANSI	1500 ANSI	2500 ANSI
Model Size	Part Number (QTY)	Part Number (QTY)	Part Number (QTY)	Part Number (QTY)	Part Number (QTY)	Part Number (QTY)
2	DC33S58-218 (11)	DC33S34-238 (2) DC33S34-300 (9)	DC33S1-258 (2) DC33S1-300 (9)	DC33S58-300 (3)	DC33S34-338 (3)	DC33S1-312 (3)
3	DC33S58-214 (14)	DC33S34-212 (2) DC33S34-300 (12)	DC33S1-234 (2) DC33S1-358 (11)	DC33S58-318 (1)	DC33S34-312 (1)	DC33S1-414 (2)
4	DC33S34-212 (14)	DC33S34-300 (2) DC33S34-358 (10)	DC33S118-338 (2)	DC33S34-312 (1)	DC33S34-418 (4)	DC33S118-414 (14)
6	DC33S34-300 (15)	DC33S1-414 (18)	DC33S114-414 (11)	DC33S34-338 (3)	N/A	DC33S114-600 (3)
8	DC33S34-338 (19)	DC33S118-458 (18)	DC33S114-400 (18)	N/A	N/A	N/A
10	DC33S34-312 (22)	DC33S118-458 (22)	DC33S114-412 (18)	N/A	N/A	N/A
12	DC33S34-334 (22)	DC33S118-458 (22)	DC33S114-412 (20)	N/A	N/A	N/A
14	DC33S34-334 (24)	Please Call		N/A	N/A	
16	DC33S1-418 (28)	Please Call		N/A	N/A	
18	DC33S1-500 (36)	Please Call		N/A	N/A	
20	DC33S1-500 (36)	Please Call		N/A	N/A	
24	DC33S1-458 (36)	Please Call		N/A	N/A	
26	Please Call			N/A		
30	DC33S118-612 (44)			N/A		

YZP = Yellow Zinc Plated



## DBB, DUAL CHAMBER / 8"+ SINGLE CHAMBER FITTING PARTS

### #33 Body Studs (DBB Meters Only)



A193 YZP CS - B7M alloy bolting. Other materials available upon request.

Short Studs					Long Studs			
	150-600 ANSI	900 ANSI	1500 ANSI	2500 ANSI	150-600 ANSI	900 ANSI	1500 ANSI	2500 ANSI
Model Size	Part Number (QTY)	Part Number (QTY)	Part Number (QTY)	Part Number (QTY)	Part Number (QTY)	Part Number (QTY)	Part Number (QTY)	Part Number (QTY)
2	DC33S58-11516 (4) DC33S58-218 (4)	DC33S58-11516 (4) DC33S58-218 (4)	Please Call	Please Call	DC33S58-638 (7) DC33S58-714 (3)	DC33S58-638 (7) DC33S58-714 (3)	Please Call	Please Call
3	DC33S58-178 (4) DC33S58-214 (4)	DC33S58-178 (4) DC33S58-214 (4)	DC33S34-212 (4) DC33S34-238 (2) DC33S34-278 (2)	Please Call	DC33S58-612 (10) DC33S58-738 (1)	DC33S58-612 (10) DC33S58-738 (1)	DC33S34-838 (10) DC33S34-878 (1)	Please Call
4	DC33S34-212 (4) DC33S34-218 (4)	DC33S34-212 (4) DC33S34-218 (4)	DC33S1-278 (2) DC33S1-300 (4) DC33S1-312 (2)	DC33S118-300 (4) DC33S118-314 (2) DC33S118-418 (2)	DC33S34-712 (10) DC33S34-812 (1)	DC33S34-712 (10) DC33S34-812 (1)	DC33S1-934 (4) DC33S1-938 (8)	DC33S118-914 (12)
6	DC33S34-218 (4) DC33S34-300 (4)	DC33S34-218 (4) DC33S34-300 (4)	DC33S1-300 (4) DC33S1-378 (4)	DC33S114-300 (4) DC33S114-418 (4)	DC33S34-800 (11) DC33S34-838 (3)	DC33S34-800 (11) DC33S34-838 (3)	DC33S1-934 (14)	DC33S114-934 (7) DC33S114-1112 (3)
8	DC33S34-218 (4) DC33S34-338 (4)	DC33S34-218 (4) DC33S34-338 (4)	DC33S118-314 (4) DC33S118-414 (4)	Please Call	DC33S34-838 (15)	DC33S34-838 (15)	DC33S118-1014 (14)	Please Call
10	DC33S34-218 (4) DC33S34-312 (4)	DC33S34-218 (4) DC33S34-312 (4)	DC33S118-314 (4) DC33S118-418 (4)	DC33S114-300 (2) DC33S114-412 (2)	DC33S34-812 (18)	DC33S34-812 (18)	DC33S118-1018 (18)	DC33S114-912 (16)
12	DC33S78-218 (4) DC33S78-334 (4)	DC33S78-238 (4) DC33S78-378 (4)	DC33S118-314 (4) DC33S118-438 (4)	Please Call	DC33S78-834 (18)	DC33S78-900 (14)	DC33S118-1034 (18)	Please Call

YZP = Yellow Zinc Plated

**#33 Body Studs (DBB Meters Only)**



**A193 YZP CS - B7M alloy bolting. Other materials available upon request.**

Short Studs			Long Studs	
	150-600 ANSI	900 ANSI	150-600 ANSI	900 ANSI
Model Size	Part Number (QTY)	Part Number (QTY)	Part Number (QTY)	Part Number (QTY)
14	DC33S34-218 (4) DC33S34-334 (4)	Please Call	DC33S34-900 (20)	Please Call
16	DC33S1-318 (4) DC33S1-378 (4)	Please Call	DC33S1-1000 (24)	Please Call
18	DC33S1-318 (6) DC33S1-434 (6)	DC33S1-318 (6) DC33S1-434 (6)	DC33S1-1118 (30)	DC33S1-1118 (30)
20	DC33S1-318 (6) DC33S1-434 (6)	Please Call	DC33S1-1118 (30)	Please Call
24	DC33S1-318 (6) DC33S1-412 (3)	Please Call	DC33S1-1158 (30)	Please Call

*YZP = Yellow Zinc Plated*

*For sizes and ANSI classes not shown, please call your local Canalta office for more details.*

## DUAL CHAMBER / 8"+ SINGLE CHAMBER, DOUBLE BLOCK & BLEED FITTING PARTS

Item	Part Number	Material	Description	Notes
01	C60DC01SS	316 SS	Equalizer Valve Assembly 	
02 ★	C60DC02	Coated Cast Iron	Operating Wrench 	
3C ★★	C90DB03C-SS	316 SS	Valve Strip Gear Plate 	
3D	BCS32-0.190-0.250-SS-SC	316 SS	Gear Plate Screws 	
5A	C60DC05AL or R	Cast Aluminum	Slide Valve Indicator Plate (includes 10-24 * 3/4" Phillips Screw) 	*machine screw sold separately Part Number: CONS15 (1)
5B	C60DC05B	316 SS	Slide Valve Indicator Pointer 	*rivets sold separately Part Number: DS4-CS (2)
10	C60DC10SS	316 SS	Bleeder Valve 	
10H ★	CL60DC10B	A105N CS	Gate Valve - 1/2" 	
10P ★	PN0.5XXS-TP316L-12	316 SS	PIPE NIPPLE 	
11 ★	BSQNC-FT-0.500-13-1.250-CS-ZY	Case Hardened 4140 CS	Clamping Bar Screw (150-900 ANSI) 	
11 ★	BSQNC-FT-0.625-11-2.500-CS-ZY	Case Hardened 4140 CS	Clamping Bar Screw (1500 2500 ANSI) 	

YZP = Yellow Zinc Plated Carbon Steel

- ★ Indicates parts also applicable to 8" and larger model sizes of the Single Chamber Orifice Fitting
- ★★ Indicates parts only used on DBB meters  
(Stainless Steel option available on most parts)



**COMMON TO ALL MODEL SIZES**

Item	Part Number	Material	Description		Notes
15	C60DC15	316 SS	Valve Carrier Spring		
16	C60DC16	316 SS	Valve Carrier Guide (Sold individually)		
16 ★	CL60DC16	316 SS	Valve Carrier Guides 16" and larger (Sold individually)		*corresponding screws Part Number: BCS28-0.250-0.500- SS-SC (2)
17A	C60DC17A	316 SS	Valve Carrier Stop Pin		
17D ★★	BCS28-0.250- 0.500-SS-SC	316SS	Stop Plate Screw		
18D	C60DC18D	18-8 SS	Valve Seat Screw		
18GH	O008-80H	HNBR	Valve Seat Grease Port Seal		
19 ★	C60DC19	1018 CS YZP	Bearing Plug		
19 ★	1260DC19A	1018 CS YZP	Extended Bearing Plug		
20 ★	C60DC20	1018 CS YZP	Stuffing Box		
20T ★★	C250DC20T	316 SS	Stuffing Box Extension (DBB only)		

- ★ Indicates parts also applicable to 8" and larger model sizes of the Single Chamber Orifice Fitting
- ★★ Indicates parts only used on DBB meters  
(Stainless Steel option available on most parts)

## DUAL CHAMBER / 8"+ SINGLE CHAMBER, DOUBLE BLOCK & BLEED FITTING PARTS

Item	Part Number	Material	Description	Notes
22A ★	C60DC22A	316 SS	Stuffing Box Gasket 	
23	C60DC23SS	316 SS	Grease Gun Assembly 	
24	C60DC24	316 SS	Grease Check Valve 	
25 ★	C60DC25	1018 CS YZP	Packing Nut 	
25A-F ★	C60DC25S2	Teflon	Teflon Packing Sleeve Set 	
26 ★	C60DC26-SS	316 SS	Stuffing Box Gland 	
26A ★	O016-80H	HNBR	Inner Gland Seal 	
26B ★	O118-80H	HNBR	Outer Gland Seal 	
28E★	C60DC28E-SS	316 SS	3/8" Bushing Retainer 	
28A ★	C60DC28A-SS	316 SS	3/4" Bushing Retainer 	
28B ★	C60DC28B-SS	316 SS	1 3/4" Bushing Retainer 	

YZP = Yellow Zinc Plated Carbon Steel

Other materials available upon request

- ★ Indicates parts also applicable to 8" and larger model sizes of the Single Chamber Orifice Fitting
- ★★ Indicates parts only used on DBB meters  
(Stainless Steel option available on most parts)

**COMMON TO ALL MODEL SIZES**

Item	Part Number	Material	Description		Notes
30	PP3/4-A105N	A105 CS, A350 CS or SS	Drain Plug - 3/4" NPT		
31	PP1/2-A105N	A105 CS, A350 CS or SS	Meter Tap & Drain Plug - 1/2" NPT		
35B ★	C60DC35B	Brass	External Shaft Roller (20" & 24")		
35B ★	2660DC35B	Brass	External Shaft Roller (26" -30")		
36 ★	*60DC36	316 SS	External Shaft		(* Replace with meter size 20, 24, 26, 28, or 30)
37C ★	C60DC37C	Brass	External Shaft Bushing (20" & 24")		
37C ★	2660DC37C	Brass	External Shaft Bushing (26"-30")		
41L(R) ★	*60DC41-L(R)	Cast Carbon Steel	Plate Carrier Guide - Left (Right)		(* Replace with meter size 20, 24, 26, 28, or 30)
41B ★	C60DC41B-SS	18-8 SS	Plate Carrier Guide Bolt		
42A ★	C60DC42A-SS	316 SS	Plate Carrier Stop		
42C ★	C60DC42C	Brass	Plate Carrier Stop Bushing		

- ★ Indicates parts also applicable to 8" and larger model sizes of the Single Chamber Orifice Fitting
- ★★ Indicates parts only used on DBB meters  
(Stainless Steel option available on most parts)



## DUAL CHAMBER / 8"+ SINGLE CHAMBER, DOUBLE BLOCK & BLEED FITTING PARTS

Item	Part Number	Material	Description		Notes
42B ★	C60DC42B-SS	18-8 SS	Plate Carrier Stop Bolt		
44A ★	C60DC44A-SS	316 SS	Travel Brake Body		
44B ★	C60DC44B	Brass	Travel Brake Band (20" & 24")		
44B ★	2660DC44B	Brass	Travel Brake Band (26" - 30")		
44C ★	C60DC44C-SS	18-8 SS	Travel Brake Adjustment Bolt		
44D ★	C60DC44D	316 SS	Travel Brake Sleeve		
44E ★	C60DC44E-SS	304 SS	Travel Brake Hex Head Bolt		
50	CDC50	Color Etched 316 SS	Specification Plate		
52	CDC52	Color Etched 316 SS	Operating Plate		
53	CDC53	Stainless Steel	Soft Seat Warning Plate		

- ★ Indicates parts also applicable to 8" and larger model sizes of the Single Chamber Orifice Fitting
- ★★ Indicates parts only used on DBB meters  
(Stainless Steel option available on most parts)

**COMMON TO ALL MODEL SIZES**

Item	Part Number	Material	Description	Notes
54	C60DC54-340B	Grease	Slide Valve Lubricant 	*other temperature rated grease available upon request
55 ★	SSH-I0.500-20-1.500-SS-SC	18-8 SS	Eccentricity Alignment Pins 	
56 ★	C60DC40A	A105 CS	Eccentricity Alignment Plugs 	
58	SSH-I0.375-16-0.750-SS-SC	18-8 SS	Plate Carrier Alignment Screw (DC) 	
58 ★	SSH-I0.375-16-1.750-SS-SC	18-8 SS	Plate Carrier Alignment Screw (SC) 	
61 ★★	GPAS-8M4F-6B-SS	316 SS	Swivel Blow Out Preventor 	

- ★ Indicates parts also applicable to 8" and larger model sizes of the Single Chamber Orifice Fitting
- ★★ Indicates parts only used on DBB meters  
(Stainless Steel option available on most parts)





# ***ORIFICE PLATES & PLATE SEALS***

## ORIFICE PLATES & PLATE SEALS

The **Type "K" Standard 2000 Edition Seal Assembly** is the standard seal supplied with all Canalta Orifice Fittings sizes 2" through 8". The assembly is comprised of a HNBR elastomer seal and stainless steel retainer ring. The single downstream seal function offers superior sealing capability while reducing seal damage during insertion. This design cuts in half the seals compressible material, resulting in less seal swell common in most applications. The durability of the stainless steel retainer ring leads to replacement costs of approximately 1/3 of other plate seals. Exact and repeatable concentricity is maintained with the metal to metal contact throughout the entire 360° circumference of the orifice plate to the plate carrier mechanism.

This unit is used with a .562" seal gap for fittings sized 2" through 6", and with a .688" seal gap for 8" fittings, meeting the 1992 and 2000 editions of AGA-3. Plate seal bypass tested down to 1" water column.



HNBR Elastomer Seal Ring			"K" Style Retainer Ring 316 Stainless Steel	
Model Size	Part Number	Notes	Part Number	Notes
2	2DC08H-00-HNBR-85D		2DC08K	
3	3DC08H-00-HNBR-85D		3DC08K	
4	4DC08H-00-HNBR-85D		4DC08K	
6	6DC08H-00-HNBR-85D		6DC08K	
8	8DC08H-00-HNBR-85D		8DC08K	

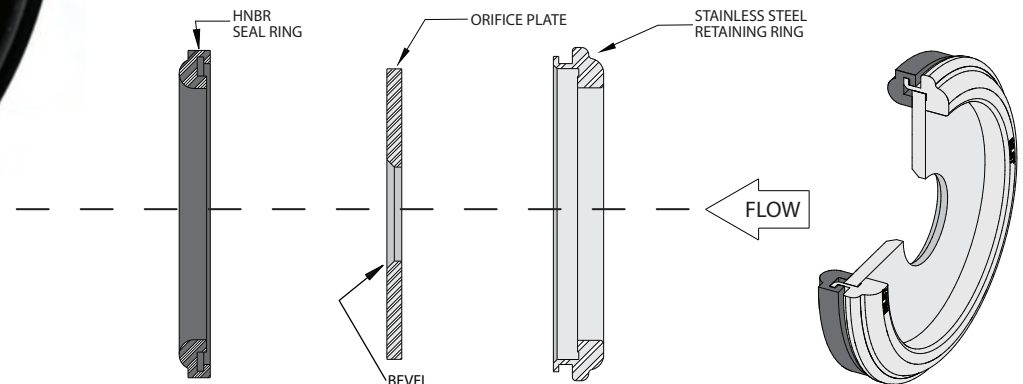

The **Teflon Snap Seal** provides positive plate sealing in the harshest of process environments. The two-piece design snaps over the orifice plate without the use of metal clips or retainers. A specially designed recess absorbs insertion pressures, minimizing permanent compression and distortion.

The raised section adjacent to the recess creates a positive seal against the orifice plate, preventing bypass leakage. These two unique design features enhance seal performance while extending the life expectancy of the seal assembly.

Teflon Snap Seals are available for 2000 Edition seal gaps. 85 Edition snap and clip-style Teflon seals are also available for some sizes. Please contact our offices for more information.

Teflon Snap Seal Set		
Model Size	Part Number	Notes
2	2DC08IJ-00-125-562	
3	3DC08IJ-00-125-562	
4	4DC08IJ-00-125-562	
6	6DC08IJ-00-125-562	
8	8DC08IJ-00-250-688	
10	10DC08IJ-00-250-688	
12	12DC08IJ-00-250-688	
14	14DC08IJ-00-250-688	
16	16DC08IJ-00-375-688	
18	18DC08IJ-00-375-813	
20	20DC08IJ-00-375-813	
24	24DC08IJ-00-500-875	
26	26DC08IJ-00-500-875	
28	28DC08IJ-00-500-875	
30	30DC08IJ-00-500-875	

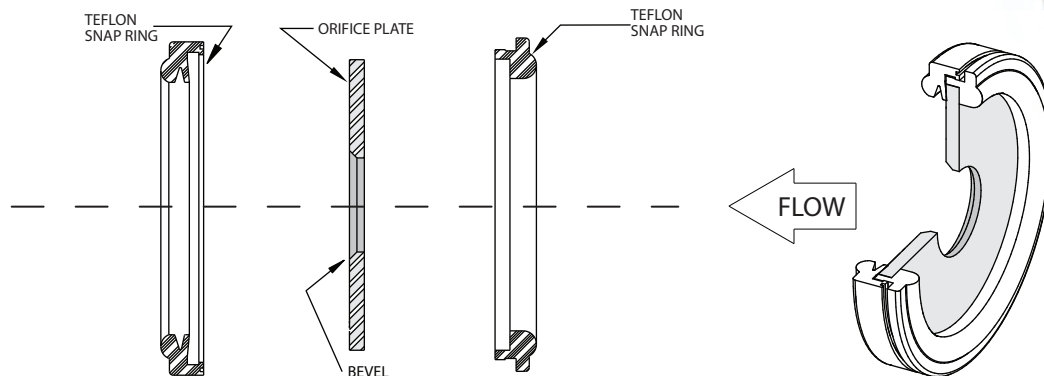



## ORIFICE PLATES & PLATE SEALS

**Notched Seals** are used only with notched plate carriers. Notched seals are available in the HNBR wrap seal version and also Teflon Snap seal assemblies. Exact and repeatable concentricity is maintained with the metal to metal contact throughout the entire 360° circumference of the orifice plate to the plate carrier mechanism.

This unit is used with a .562" seal gap for fittings sized 2" through 6", and with a .688" seal gap for 8" fittings, meeting the 1992 and 2000 editions of AGA-3. Plate seal bypass tested down to 1" water column.

*Notched Teflon Snap Seal*

*Notched Wrap Seal*



**Notched Teflon Snap Seal**

Model Size	Part Number	Notes
2	2DC08ST-00-125-562	
3	3DC08ST-00-125-562	
4	4DC08ST-00-125-562	
6	6DC08ST-00-125-562	
8	8DC08ST-00-250-562	

**Notched HNBR Wrap Seal**

Model Size	Part Number	Notes
2	2DC08R-HNBR-125-562-85D	
3	3DC08R-HNBR-125-562-85D	
4	4DC08R-HNBR-125-562-85D	
6	6DC08R-HNBR-125-562-85D	
8	8DC08R-HNBR-250-562-85D	

**O-ring Style Seals** are available in a Teflon Snap Seal and full Stainless Steel versions. With a combination of an internal o-ring seal and an external o-ring on the downstream face of the plate assembly, optimum sealing is achieved.

The Teflon O-ring snap seal is available in sizes 2" through to 12". The full stainless steel version is available in sizes 2" through to 24".

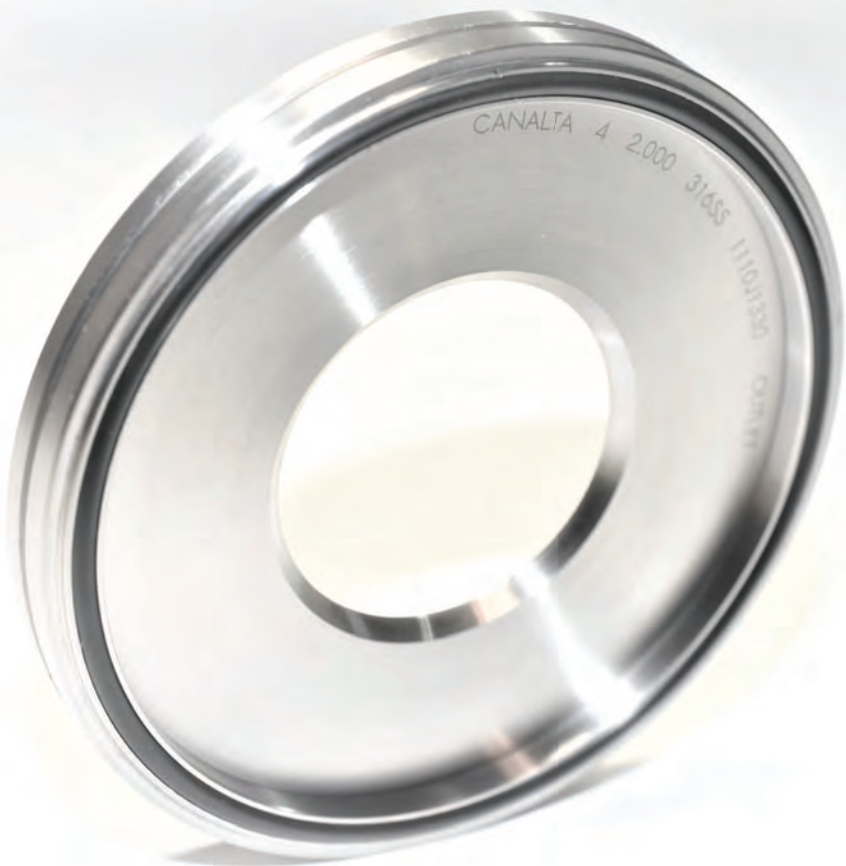

O-ring Style Seal Teflon			
Model Size	Part Number	O-ring	Notes
2	2DC08LM-00-125-562	O228-80H	
3	3DC08LM-00-125-562	O236-80H	
4	4DC08LM-00-125-562	O244-80H	
6	6DC08LM-00-125-562	O259-80H	
8	8DC08LM-00-250-688	O267-80H	
10	10DC08LM-00-250-688	O275-80H	
12	12DC08LM-00-250-688	O278-80H	

O-ring Style Seal - Stainless Steel			
Model Size	Part Number	O-ring	Notes
2	2DC08PQ-00-125-562	O228-80H	
3	3DC08PQ-00-125-562	O236-80H	
4	4DC08PQ-00-125-562	O244-80H	
6	6DC08PQ-00-125-562	O259-80H	
8	8DC08PQ-00-250-688	O267-80H	
10	10DC08PQ-00-250-688	O275-80H	
12	12DC08PQ-00-250-688	O278-80H	
14	14DC08PQ-00-250-688	Contact Factory	
16	16DC08PQ-00-375-813	O384-80H	
18	18DC08PQ-00-375-813	O388-80H	
20	20DC08PQ-00-500-875	O388-80H	
24	24DC08PQ-00-500-875	Contact Factory	

## ORIFICE PLATES & PLATE SEALS

The **Bonded "FLEX" Seal** is designed with a unique "hollow core" recess, this seal has impressive expansion and contraction capabilities when compared to traditional solid rubber seals. The recess allows the seal to absorb insertion pressures, minimizing tearing, distortion and permanent compression. This design will also accommodate expansion and distortion in the seal gap when under pressure - a problem common to many large-sized fittings.

The 70 Durometer HNBR seal is adhesively bonded to the orifice plate, creating total and permanent contact between the plate and seal and preventing bypass leakage. These units are typically supplied as seal and orifice plate packages and are available for model sizes 10" and larger.



HNBR Bonded Flex Seal		
Model Size	Part Number	Notes
10	10DC08H-FLEX-HNBR-250-688-70D	
12	12DC08H-FLEX-HNBR-250-688-70D	
14	14DC08H-FLEX-HNBR-250-688-70D	
16	16DC08H-FLEX-HNBR-375-688-70D	
18	18DC08H-FLEX-HNBR-375-813-70D	
20	20DC08H-FLEX-HNBR-375-813-70D	
24	24DC08H-FLEX-HNBR-500-875-70D	
26	26DC08H-FLEX-HNBR-500-875-70D	
28	28DC08H-FLEX-HNBR-500-875-70D	
30	30DC08H-FLEX-HNBR-500-875-70D	

HNBR Bonded plates are available in various plate thicknesses. Please contact the sales department for more info

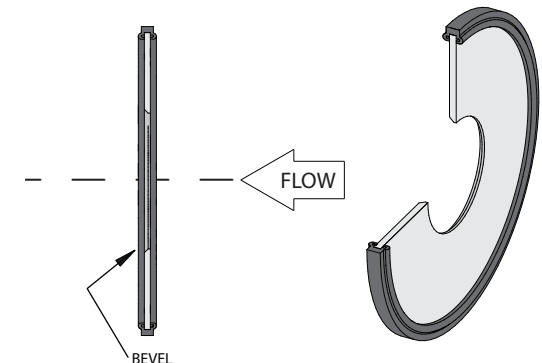



## Clip Style Teflon Snap Seal

Canalta supplies a selection of legacy plate seals for situations in which direct and exact seal replacement is required or preferred. Models include two piece **Clip-style Teflon** seal assembly. Once assembled around the orifice plate the steel clip ensures that the teflon assembly does not become accidentally separated during plate removal.

Size and pipe schedule availability varies by model. Please contact us for more information.  
(\*\* denotes pipe schedule)

*Clip-style Teflon*

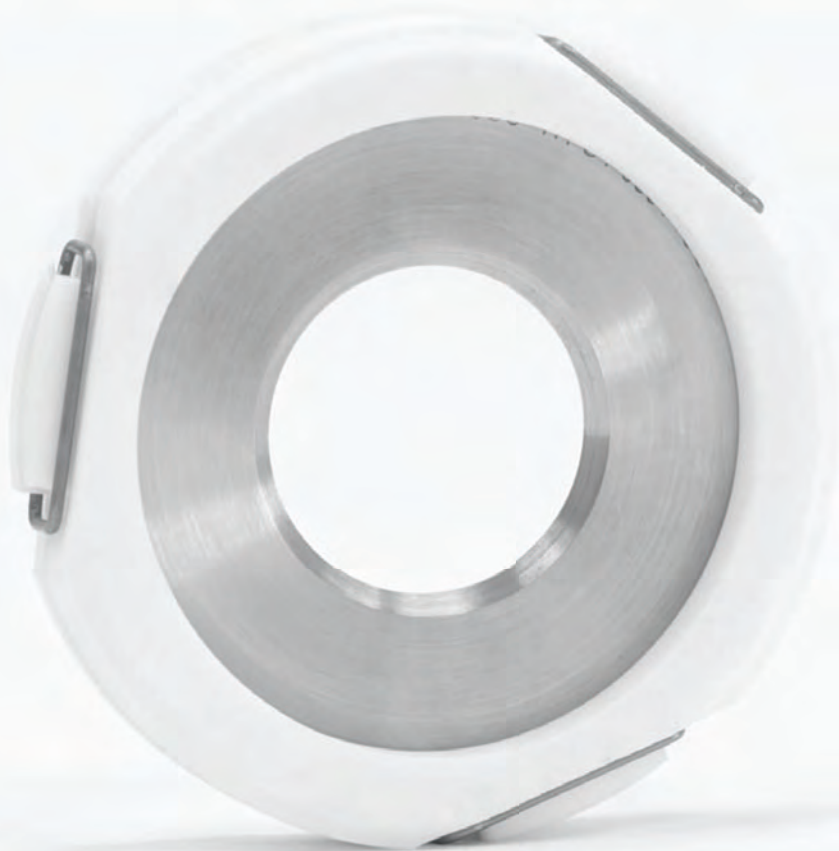

Clip-style Teflon Snap Seal		
Model Size	Part Number	Notes
2	2DC08FT-**-125-688	
3	3DC08FT-**-125-688	
4	4DC08FT-**-125-688	
6	6DC08FT-**-125-688	
8	8DC08FT-**-125-688	
10	10DC08FT-**-250-688	
12	12DC08FT-**-250-688	
14	14DC08FT-**-250-688	
16	16DC08FT-**-375-688	

We will also work with you to custom design and manufacture purpose-built seals for your unique or special

## ORIFICE PLATES & PLATE SEALS

The **Wrap Around Seal** provides positive plate sealing. The one-piece design stretches over the orifice plate without the use of metal clips or retainers. A specially designed recess absorbs insertion pressures, minimizing permanent compression and distortion.

The raised section adjacent to the recess creates a positive seal against the orifice plate preventing bypass leakage. These two unique design features enhance seal performance while extending the life expectancy of the seal.

Available in 2" through to 12" and in HNBR.  
 (\*\* denotes pipe schedule)

Wrap Around Seal - HNBR		
Model Size	Part Number	Notes
2	2DC08FH-**-125-688-80D	
3	3DC08FH-**-125-688-80D	
4	4DC08FH-**-125-688-80D	
6	6DC08FH-**-125-688-80D	
8	8DC08FH-**-125-688-80D	
10	10DC08FH-**-250-688-80D	
12	12DC08FH-**-250-688-80D	



---

*NOTES*



## ORIFICE PLATES & PLATE SEALS

**Canalta** has been a trusted supplier of AGA-3 / API 14.3 and ISO 5167-2 compliant orifice plates for years. We stock a wide selection of standard concentric universal orifice plates for gas and liquid flow measurement in 316 stainless steel. These units are perfect for any Single or Dual Chamber Orifice Fitting.

Paddle plates for use with Orifice Flange Unions and orifice plates for special applications are available. Canalta also supplies orifice plates in exotic materials, such as Monel™, Inconel™ and Hastelloy™.

Canalta can provide comprehensive Orifice Plate Inspection Reports complete with calibration certificates and mill test reports.

Restriction Orifice plates are also offered as part of an engineered solution.

**Contact us today** to find out more about our competitive pricing and and quick delivery times on all types of orifice plates.

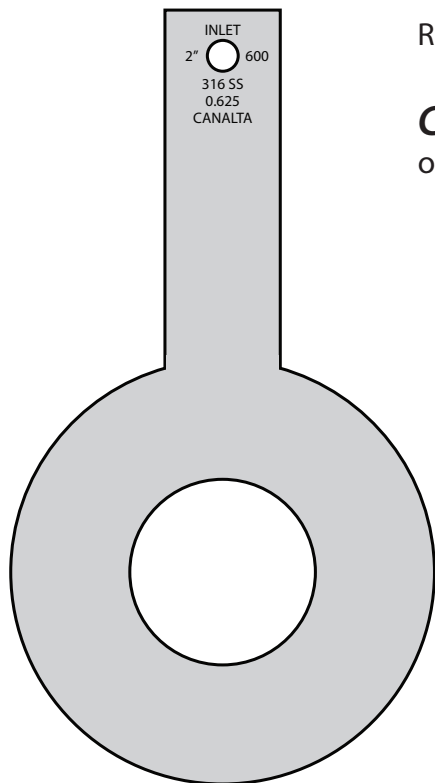

Concentric Paddle Plate

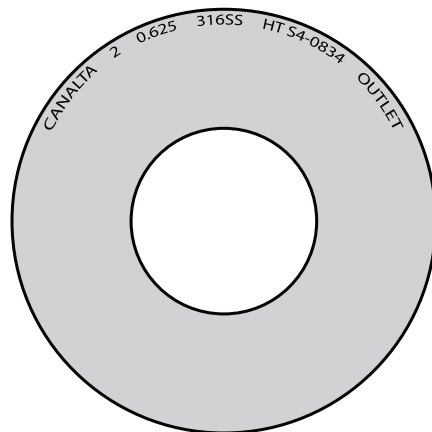

Concentric Universal Plate

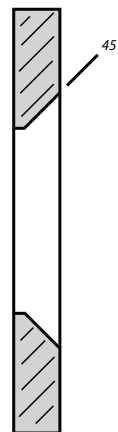

Bevel Profile

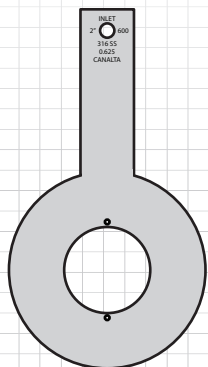
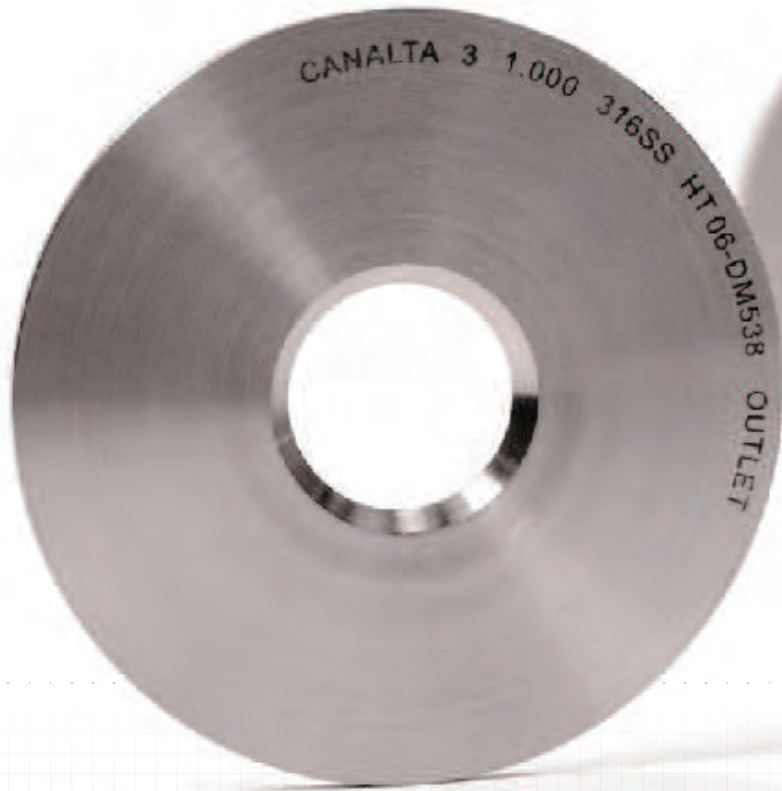

Vented Orifice Plate

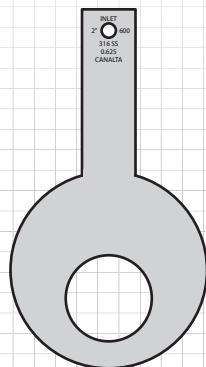

Eccentric Orifice Plate

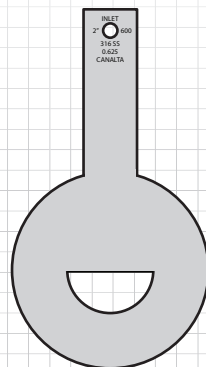

Segmental Orifice Plate

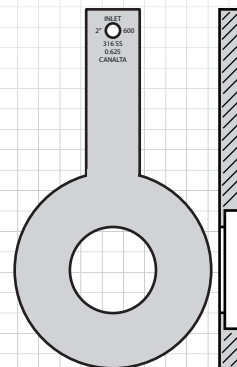

Counter-bored Orifice Plate

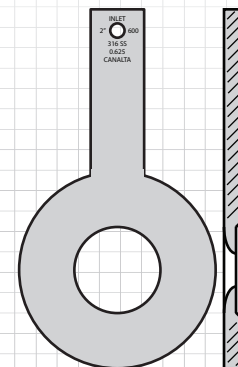

Quadrant-bored Orifice Plate

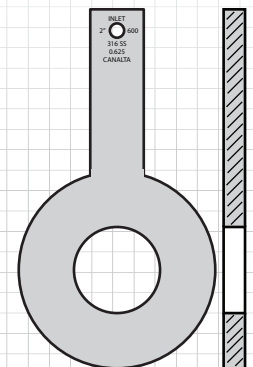

Concentric Restriction Plate

**Canalta** 

*Flow Measurement*

An ISO 9001:2015 Registered Company

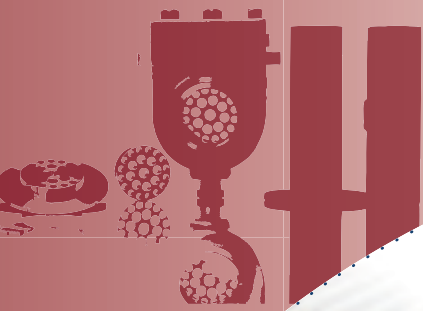

# ***FLOW CONDITIONING SOLUTIONS***





# Contour™

## Flow Conditioning Solutions

by **Canalta**

**Contour™ K5 and Z Flow Conditioners** maximize orifice meter accuracy while significantly reducing upstream pipe length requirements. This common design fully develops the flow profile and helps to eliminate flow disturbances without creating a significant pressure drop. Accurate flow metering is possible in a host of line configurations, including multiple elbows in or out of plane, tee intersections and partially closed or nominally opened valves. Installation, maintenance and initial capital cost are easy and economical, and the resilient one-piece design ensures a long service life. Standard 316 stainless steel makes these flow conditioners suitable for all applications, including extremely corrosive environments.

**Contour™ K5 Flow Conditioners** are designed and manufactured to the exact geometries of the popular K-Lab / Nova design (CPA 50E®) which has achieved broad acceptance within the flow measurement industry. **Contour™ Z Flow Conditioners** include the 32-hole Zanker plate geometry. Contour™ Z Flow Conditioners are only available in flange style.

**Flange-style Flow Conditioners** are installed between two raised face or ring-type joint flanges upstream of the orifice plate. Available for pipe sizes 2" through 30" in all standard schedules, with custom schedules by special order.

**Pin-style Flow Conditioners** are line mounted with a set pin in the wall of the upstream pipe. Available for pipe sizes 2" through 4" in all standard schedules, with custom schedules by special order.

Other types of Flow Conditioner also available include 'Zanker', 'Gallagher', 'Spearman'. Customer specific solutions also considered.

Contact one of our sales representatives today for full details, technical specifications and ordering information.

Note: CPA 50E is a registered trademark of Canada Pipeline Accessories Co. Ltd. Daniel Industries, Inc. (Zanker) and Canada Pipeline Accessories are not affiliated with Canalta Flow Measurement in any manner, nor have they reviewed, sanctioned or endorsed any products manufactured, reconditioned, sold or marketed by Canalta Flow Measurement.

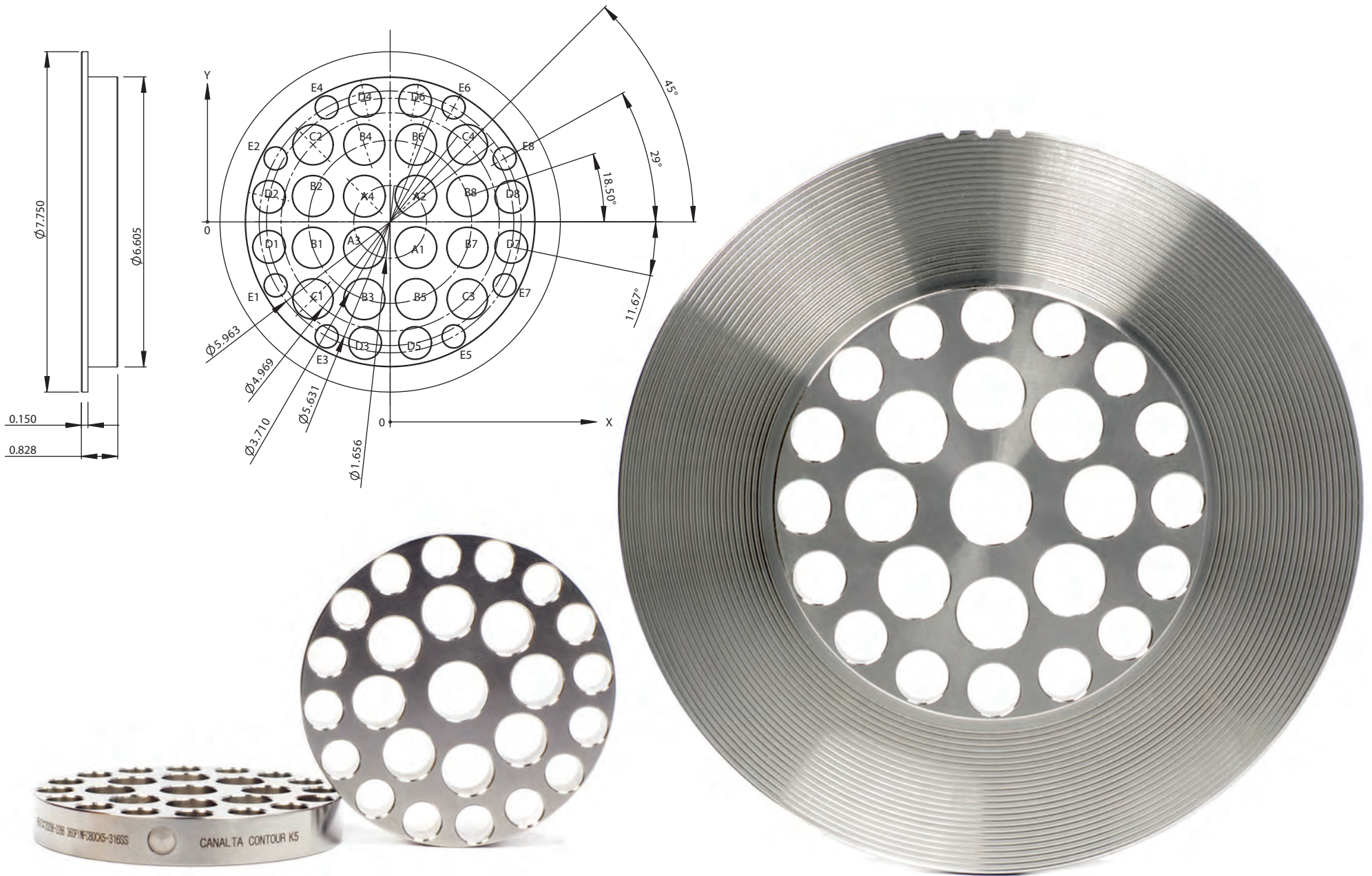

## FLANGE & PIN STYLE FLOW CONDITIONERS

Canalta Contour Flow Conditioners for installation upstream of the primary meter are available as Pin type (PIN), Raised Face (RF) and Ring Type Joint (RTJ) formats. Common Flow Conditioner types available are Contour™ and Zanker with custom schedules by special order.

Part Numbering format is as follows;

SIZE - Pin Type: 2", 3" or 4", Flanged Type: 2"-30" (larger sizes available upon request)

ANSI - 60 (150-900 ANSI)\*, 150 (1500 ANSI), 250 (2500 ANSI)\*

CON - Connection type - PIN, (available from 150-2500 ANSI) IG (Integral Gasket for 2" Contour only, 150-600 ANSI with part no. "260" and 900-2500 ANSI with part no. "2150")\*, RF (Raised Face)\*, RJ (Ring Type Joint)\*

SCH - Pipe Schedule

TYPE - CONTOUR™ (CK5), ZANKER (ZAN)

MATERIAL - 316 SS, DUPLEX (2205), SUPER DUPLEX (2507)

Worked Example:

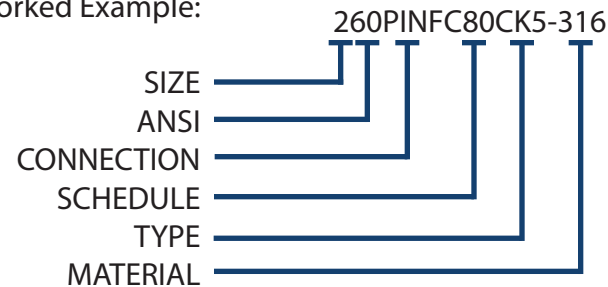

CONTOUR™ K5 - PIN TYPE		
Model Size	Part Number	Notes
2	260PINFC**CK5-316SS	
3	360PINFC**CK5-316SS	
4	460PINFC**CK5-316SS	

\* Flange Type only

\*\* Pipe Schedule



CONTOUR™ K5 FLOW CONDITIONER			ZANKER FLOW CONDITIONER	
	CONTOUR™ K5 RAISED FACE (RF)	CONTOUR™ K5 RING TYPE JOINT (RTJ)	ZANKER RAISED FACE (RF)	ZANKER RING TYPE JOINT (RTJ)
Model Size	Part Number	Part Number	Part Number	Part Number
2	2*IGFC**CK5-316SS	2*RJFC**CK5-316SS	260IGFC**ZAN-316SS	2*RJFC**ZAN-316SS
3	360RFFC**CK5-316SS	3*RJFC**CK5-316SS	360RFFC**ZAN-316SS	3*RJFC**ZAN-316SS
4	460RFFC**CK5-316SS	4*RJFC**CK5-316SS	460RFFC**ZAN-316SS	4*RJFC**ZAN-316SS
6	660RFFC**CK5-316SS	6*RJFC**CK5-316SS	660RFFC**ZAN-316SS	6*RJFC**ZAN-316SS
8	860RFFC**CK5-316SS	8*RJFC**CK5-316SS	860RFFC**ZAN-316SS	8*RJFC**ZAN-316SS
10	1060RFFC**CK5-316SS	10*RJFC**CK5-316SS	1060RFFC**ZAN-316SS	10*RJFC**ZAN-316SS
12	1260RFFC**CK5-316SS	12*RJFC**CK5-316SS	1260RFFC**ZAN-316SS	12*RJFC**ZAN-316SS
14	1460RFFC**CK5-316SS	14*RJFC**CK5-316SS	1460RFFC**ZAN-316SS	14*RJFC**ZAN-316SS
16	1660RFFC**CK5-316SS	16*RJFC**CK5-316SS	1660RFFC**ZAN-316SS	16*RJFC**ZAN-316SS
18	1860RFFC**CK5-316SS	18*RJFC**CK5-316SS	1860RFFC**ZAN-316SS	18*RJFC**ZAN-316SS
20	2060RFFC**CK5-316SS	20*RJFC**CK5-316SS	2060RFFC**ZAN-316SS	20*RJFC**ZAN-316SS
24	2460RFFC**CK5-316SS	24*RJFC**CK5-316SS	2460RFFC**ZAN-316SS	24*RJFC**ZAN-316SS
26	2660RFFC**CK5-316SS	26*RJFC**CK5-316SS	2660RFFC**ZAN-316SS	26*RJFC**ZAN-316SS
30	3060RFFC**CK5-316SS	30*RJFC**CK5-316SS	3060RFFC**ZAN-316SS	30*RJFC**ZAN-316SS

\* ANSI Class

\*\* Pipe Schedule



# Contour™



## Flow Conditioning Solutions

by **Canalta**

The Contour™ FCH (Flow Conditioner Housing) similar to the practicality of inspecting and changing an orifice plate, the Contour™ FCH (Flow Conditioner Housing) allows for regular inspections of the flow conditioner without breaking apart the flow line. The Contour™ FCH allows the operator to easily perform flow conditioner inspection and maintenance on the same regular schedule as the orifice plate. With this innovative, newly patented design, you can be sure that your flow profile has not been degraded by damage, blockage or residue accumulation.

All bore surfaces and internal dimensions within the housing are manufactured to strictly comply with the latest editions of AGA-3 and ISO-5167. The Contour™ FCH is effective for both ultrasonic and differential pressure custody transfer applications, where flow profile and measurement accuracy are critical.

The body connects to the line upstream of the flow conditioning plate through an **integral body flange**. This design virtually eliminates flow disturbances caused by flange breaks, making your flow profile that much more reliable. Approved for 150 - 900 ANSI ratings, these integral body flanges also reduce costs by eliminating material and fabrication procedures.



Canalta's Contour FCH utilizes the new Contour™ K5+ and Z+ flow conditioners. These isolating flow conditioners incorporate a non-protruding HNBR seal around the downstream face to prevent bypass leakage and protect the integrity of your flow profile.



Single Chamber Contour™ FCH  
(US Patent 7, 806,145)

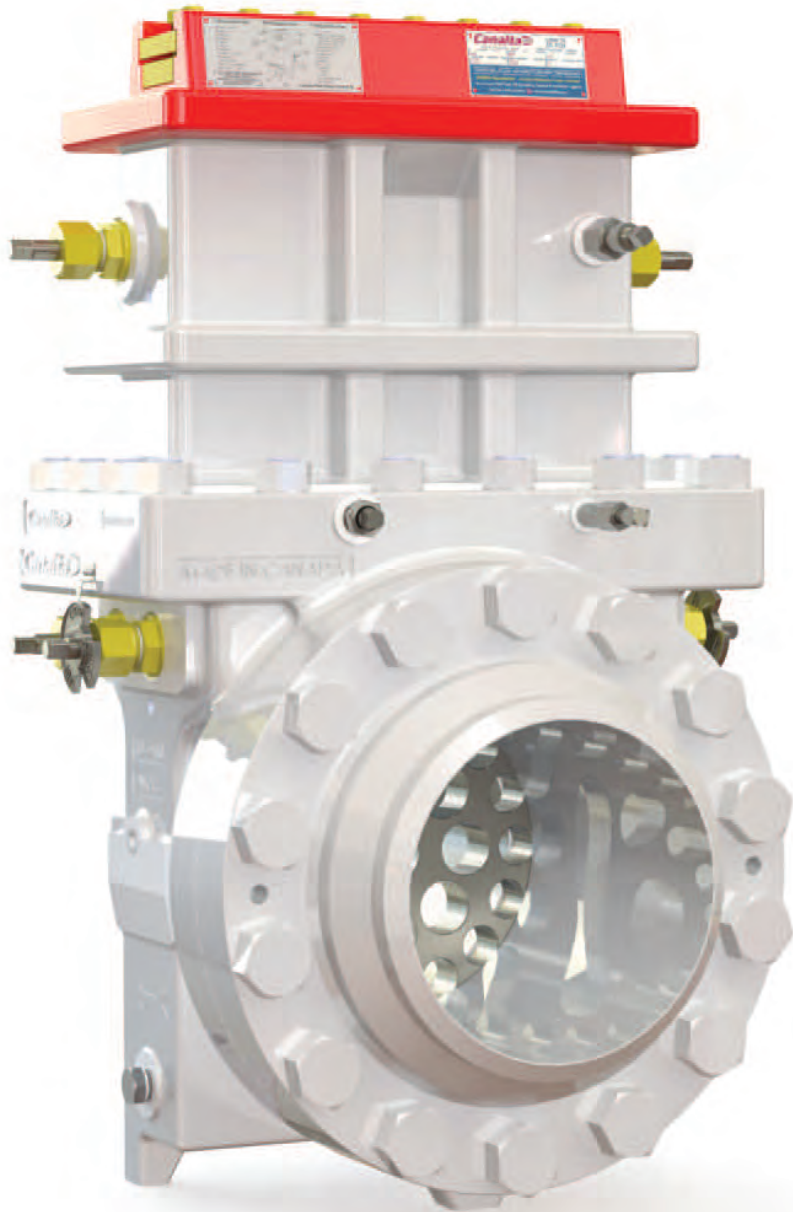

*Dual Chamber Contour™ FCH  
(US Patent 7, 806,145)*

## *Key Features:*

- Effective in all flow measurement applications where flow profile is critical for accuracy.
- Maintains flow conditioner alignment and positioning despite replacement or debris impact.
- Prevents bypass leakage.
- Allows for easy flow conditioner inspection, removal and replacement.
- Effective in both retrofits and new projects.
- Available in sizes 2" - 12" NPS.
- Can be fitted for standard or extreme corrosive service.
- Available in both single and dual chamber designs.

## 2-6" 150-900 ANSI SINGLE CHAMBER FLOW CONDITIONER HOUSING

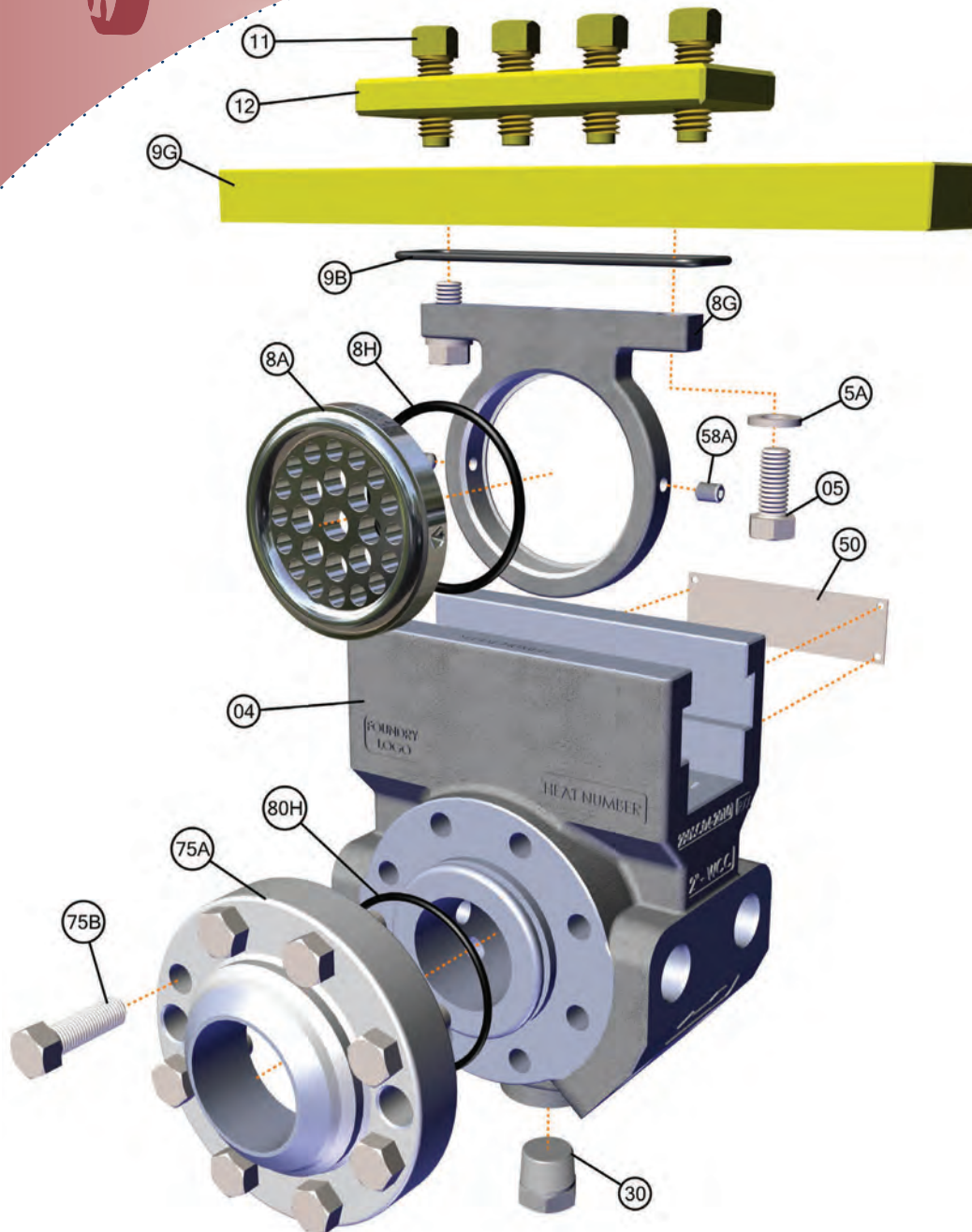

Part	Qty.	Description
04	1	Flangeneck Body
05	2	Plate Carrier Bolt
5A	2	Lock Washer
8A	1	Flow Conditioner
8G	1	Plate Carrier
8H	1	Flow Conditioner Seal
9G	1	Seal Bar
9B	1	Seal Bar O-ring
11	A/R	Clamping Bar Screw
12	1	Clamping Bar
30	1	Drain Plug
50	1	Specification Plate
51	1	Warning Plate
58A	2	Flow Conditioner Plate Carrier Screw
75A	1	Integral Flange
75B	A/R	Integral Flange Bolt
80H	1	Integral Flange O-ring

A/R = As Required per Model Size



## 8-12" 150-900 ANSI SINGLE CHAMBER FLOW CONDITIONER HOUSING

Part	Qty.	Description
02	1	Operating Wrench
04	1	Flangeneck Body
4A	1	Body O-ring
5C	1	Dual Shaft & Pinion Gear
08	1	Plate Carrier
8A	1	Flow Conditioner Plate
8H	1	Flow Conditioner Seal
9B	1	Seal Bar O-ring
9G	1	Seal Bar
11	A/R	Clamping Bar Screw
12	1	Clamping Bar
14	1	Top Housing
19	2	Bearing Plug
20	2	Stuffing Box
20A	2	Stuffing Box Outer Gland Seal
22A	4	Stuffing Box Gasket
25	2	Packing Nuts
25A-F	A/R	Packing Sleeve
25S	1	Complete Packing Set
26	2	Stuffing Box Glands
26A	2	Stuffing Box Inner Gland Seal
28A	A/R	Bushing Retainer - Stuffing Box
28B	A/R	Bushing Retainer - Stuffing Box
30	2	Drain Plug
32	A/R	Hex Head Nut

Part	Qty.	Description
33	A/R	Body Stud
50	1	Specification Plate
55	3	Eccentricity Alignment Pin
56	3	Eccentricity Alignment Plug
58A	1	Plate Carrier Alignment Screw
58B	2	Flow Conditioner Plate Carrier Screw
70	1	Pinion Gear Assembly
75A	1	Integral Flange
75B	1	Integral Flange Bolts
80H	1	Integral Flange O-ring

A/R = As Required per Model Size

### 70 - GEAR SHAFT COMPONENTS

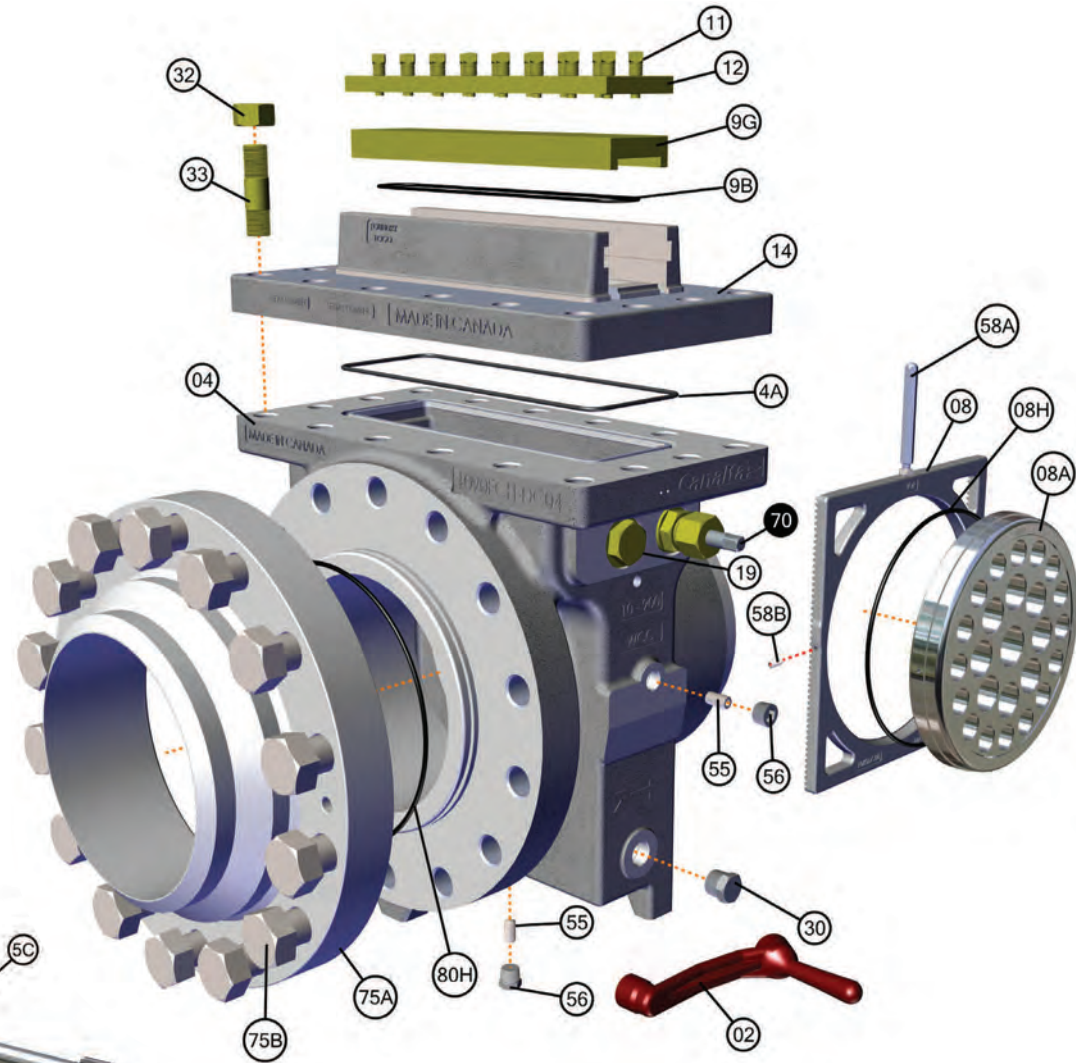
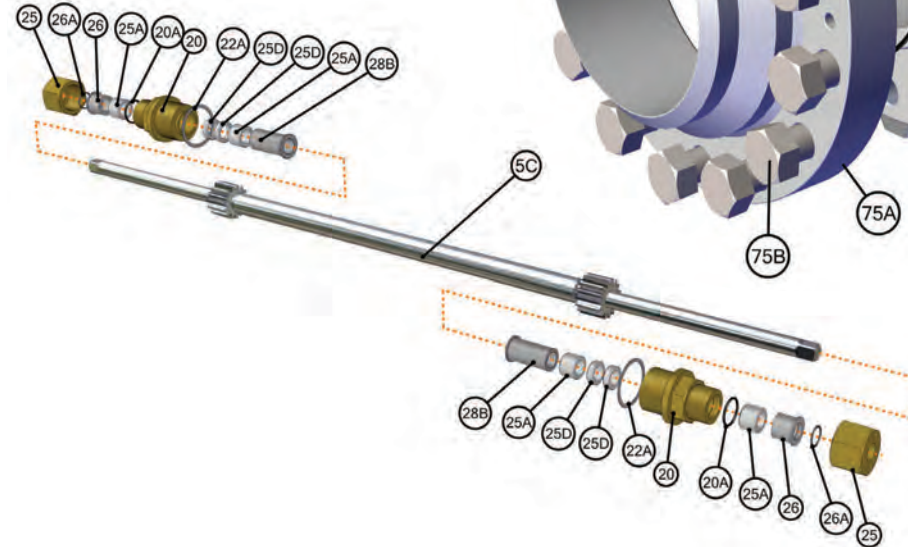



## 2-12" SINGLE CHAMBER FLOW CONDITIONER HOUSING PARTS

#8G Flow Conditioner Plate Carrier



CF8M Stainless Steel

Model Size	Part Number	Notes
2	260SC08-92-SS	
3	360SC08-92-SS	
4	460SC08-92-SS	
6 *	660SC08-92-SS	

\* Only applicable to 6" High Pressure models

#8 Flow Conditioner Plate Carrier

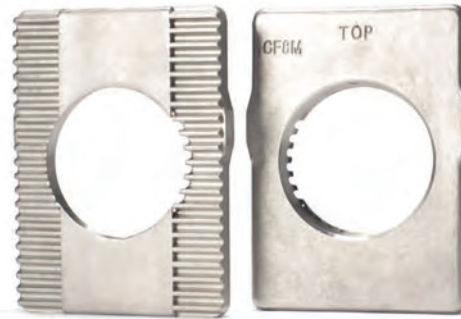

Downstream Face View

Upstream Face View

CF8M Stainless Steel

Model Size	Part Number	Notes
6	660DC08-92-SS	
8	860DC08-92-SS	
10	1060DC08-92-SS	
12	1260DC08-92-SS	

#9B FCH Seal Bar O-ring



HNBR Rubber

Model Size	Part Number	Notes
2	O238-80H	
3	O243-80H	
4	O247-80H	
6	O259-80H	
8	O266-80H	
10	O271-80H	
12	O276-80H	

VARIABLE BY MODEL SIZE

#9G FCH Seal Bar

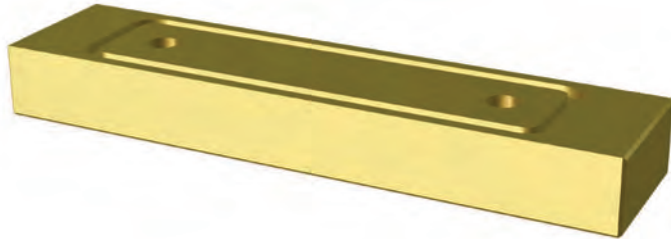

Available for 150 - 900 or 1500/2500 ANSI ratings in 1018 YZP carbon steel.  
Requires one seal bar O-ring (#9B).

150 - 900 ANSI		1500 & 2500 ANSI	
Model Size	Part Number	Part Number	Notes
2	290FCH-SC09G-2010	Please Call	
3	390FCH-SC09G-2010	Please Call	
4	490FCH-SC09G-2010	Please Call	
6	690FCH-SC09G-2010	Please Call	
8	890FCH-SC09G-2010	Please Call	
10	1090FCH-SC09G-2010	Please Call	
12	1290FCH-SC09G-2010	Please Call	

#5C Dual Shaft & Pinion Gears

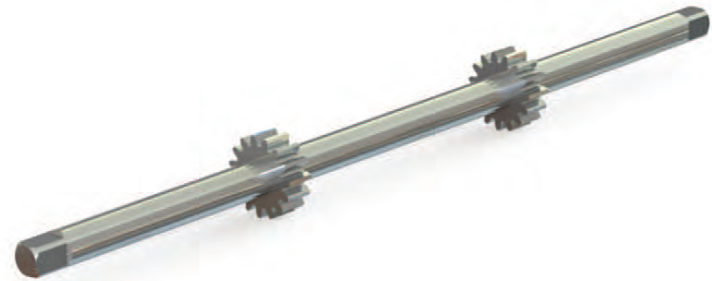

CF8M Stainless Steel

Model Size	Part Number	Notes
6	660DC05C-SS	
8	860DC05C-SS	
10	1060DC05C-SS	
12	1260DC05C-SS	

Other materials available upon request.

## 2-12" SINGLE CHAMBER FLOW CONDITIONER HOUSING PARTS

**#12 FCH Clamping Bar**



Available for 150 - 2500 ANSI ratings in 1018 YZP carbon steel.  
Requires corresponding clamping bar screws (#11).

150 - 900 ANSI		1500 / 2500 ANSI	
Model Size	Part Number	Part Number	Notes
2	290FCH-SC12-2010	Please Call	
3	390FCH-SC12-2010	Please Call	
4	490FCH-SC12-2010	Please Call	
6	690FCH-SC12-2010	Please Call	
8	890FCH-SC12-2010	Please Call	
10	1090FCH-SC12-2010	Please Call	
12	1290FCH-SC12-2010	Please Call	

**#8A Flow Conditioner**



Suitable for SC and DC Flow Conditioner Housings.  
316 Stainless Steel as standard. Universal part numbers for 150-2500 ANSI.  
Other materials upon request.







Contour™ K5+ Flow Conditioner		
Model Size	Part Number	Notes
2	290CK508A-*	
3	390CK508A-*	
4	490CK508A-*	
6	690CK508A-*	
8	890CK508A-*	
10	1090CK508A-*	
12	1290CK508A-*	

**Notes:**

Zanker type flow conditioners are available for use in the Flow Conditioner Housings upon request.

\* Pipe Schedule

COMMON TO ALL MODEL SIZES

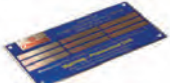
Item	Part Number	Material	Description	Notes
05	C60SC05	316 SS	Plate Carrier Bolt 	
5A	C60SC05A	316 SS	Plate Carrier Lock Washer 	
11 ★	BSQNC-FT-0.500-13-1.250-CS-ZY	Case Hardened 4140 CS	Clamping Bar Screw (150-900 ANSI) 	
11 ★	BSQNC-FT-0.625-11-2.500-CS-SC	Case Hardened 4140 CS	Clamping Bar Screw (1500 /2500 ANSI) 	
30	PP3/4-A105N or PP3/4-A350	A105 CS	Drain Plug - 3/4" NPT 	
31	PP1/2-A105N or PP1/2-A350	A105 CS	Drain Plug - 1/2" NPT 	
50	CSC50	Color Etched 316 SS	Specification Plate 	

(Stainless Steel option available on most parts)



## 2-12" 150 - 900 ANSI DUAL CHAMBER FLOW CONDITIONER HOUSING

Note: Meter shown is Grease Seat design

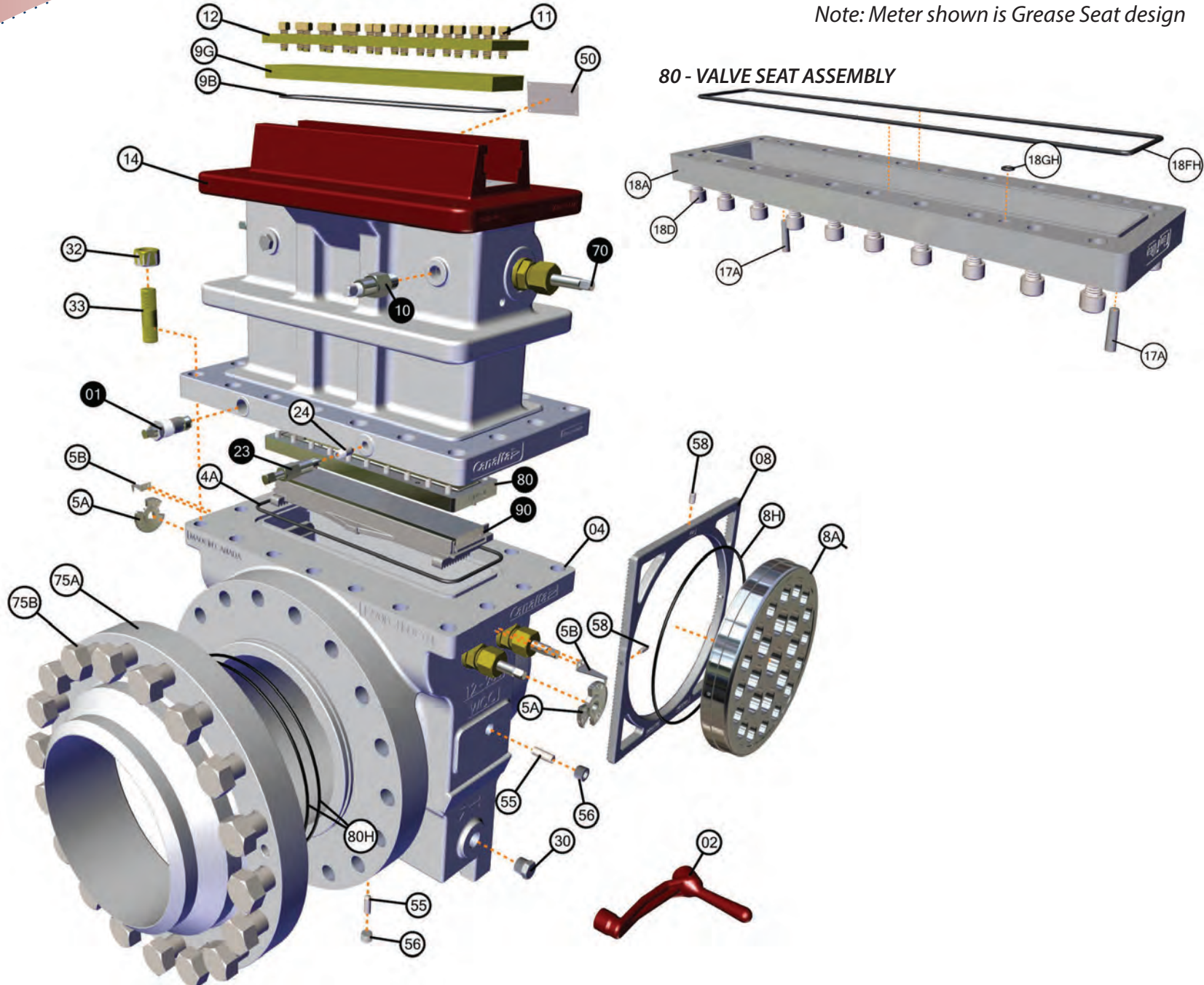

**70 - GEAR SHAFT COMPONENTS**

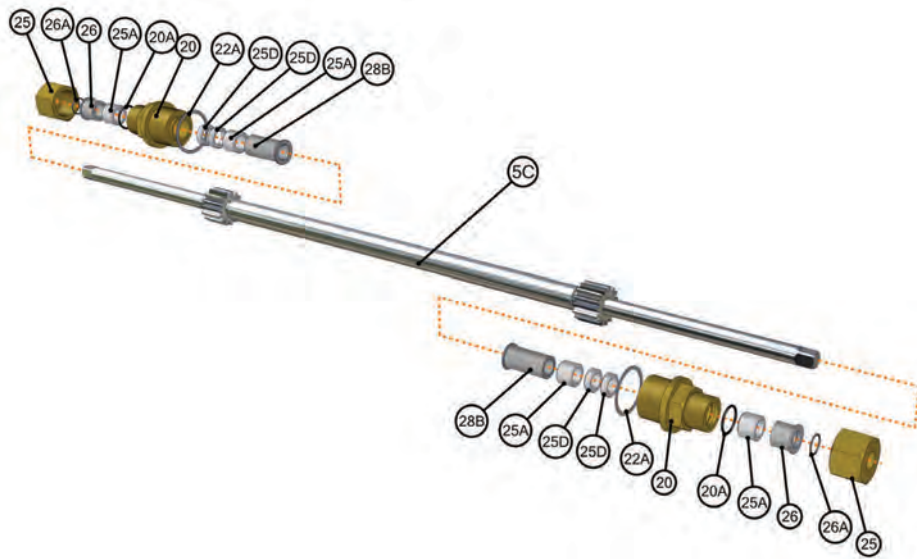

**90 - CLIPPER VALVE ASSEMBLY**

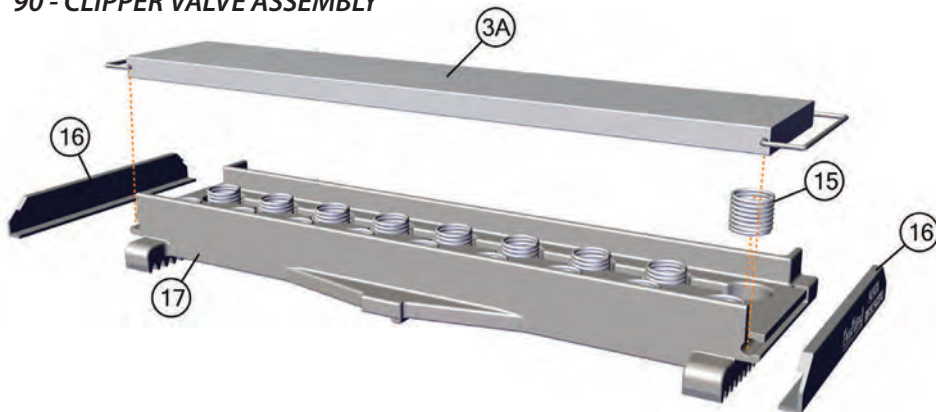

Part	Qty.	Description	Part	Qty.	Description
01	1	Equalizer Valve Assembly	18FH	1	Valve Seat Top O-ring
02	1	Operating Wrench	18GH	A/R	Valve Seat Grease Port Seal
3A	1	Valve Strip	20	6	Stuffing Box
04	1	Flangeneck Body	20A	6	Stuffing Box Outer Gland Seal
4A	1	Body O-ring	22A	6	Stuffing Box Gasket
5C	3	Dual Shaft & Pinion Gear	23	1	Grease Gun Assembly
5A	2	Slide Valve Indicator Plate	24	1	Double Ball Grease Check Valve
5B	2	Slide Valve Indicator Pointer	25	3	Packing Nuts
08	1	Plate Carrier	25A-F	A/R	Packing Sleeve
8A	1	Flow Conditioner	25S	2	Complete Packing Set
8H	1	Flow Conditioner O-Ring	26	6	Stuffing Box Glands
9B	1	Seal Bar O-ring	26A	3	Stuffing Box Inner Gland Seal
9G	1	Seal Bar with O-ring Groove	28A	A/R	Bushing Retainer - Stuffing Box
10	1	Bleeder Valve	28B	A/R	Bushing Retainer - Stuffing Box
11	A/R	Clamping Bar Screw	30	2	Drain Plug
12	1	Clamping Bar	32	A/R	Body Hex Nut
14	1	Top Housing	33	A/R	Body Stud
15	A/R	Valve Carrier Spring	50	1	Operating Instruction Plate
16	2	Valve Carrier Guide	52	1	Specification Plate
17B	1	Valve Carrier	54	A/R	Slide Valve Lubricant
17A	2	Valve Carrier Stop Pin	55	3	Eccentricity Alignment Pin
18A	1	Valve Seat (Grease type)	56	3	Eccentricity Alignment Plug
18D	A/R	Valve Seat Screw	58	1	Plate Carrier Alignment Screw
			75A	A/R	Integral Flange
			75B	A/R	Integral Flange Bolt
			80H	1	Integral Flange O-ring

A/R = As Required per Model Size

## 2-12" DUAL CHAMBER FLOW CONDITIONING HOUSING PARTS

### #08 Plate Carrier

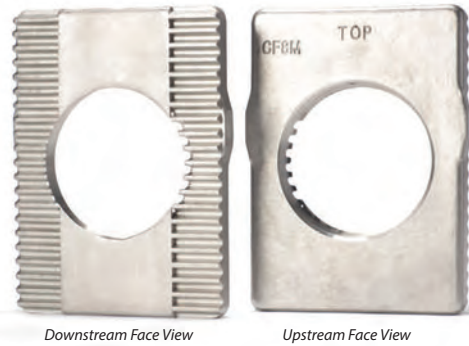

Downstream Face View

Upstream Face View

CF8M Stainless Steel

Model Size	Part Number	Notes
2	260DC08-92-SS	
3	360DC08-92-SS	
4	460DC08-92-SS	
6	660DC08-92-SS	
8	860DC08-00-625-SS	
10	1060DC08-SS	
12	1260DC08-SS	

### #5C Dual Shaft & Pinion Gears

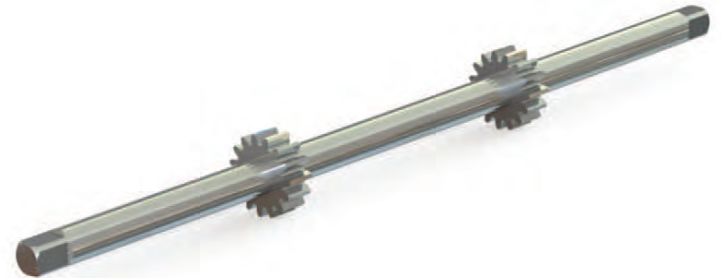

CF8M Stainless Steel

Model Size	Part Number	Notes
2	260DC05C-SS	
3	360DC05C-SS	
4	460DC05C-SS	
6	660DC05C-SS	
8	860DC05C-SS	
10	1060DC05C-SS	
12	1260DC05C-SS	

**VARIABLE BY MODEL SIZE**

**#90 Clip Style Valve Assembly**



Other materials available upon request.

**CF8M Stainless Steel**

Model Size	Part Number	Notes
2	2150DC90-SS	
3	3150DC90-SS	
4	4150DC90-SS	

**Note:** 'Clipper' style valve only on 2", 3" and 4".

**#3A Valve Strip**



**A564 Gr.630 Stainless Steel**

Model Size	Part Number	Notes
2	260DC03A	
3	360DC03A	
4	460DC03A	
6	690FCH-DC03A	
8	890FCH-DC03A	
10	1090FCH-DC03A	
12	1290FCH-DC03A	

**Note:** 'A' suffix denotes clipper compatible component

**#17B Valve Carrier**



**CF8M Stainless Steel**

Model Size	Part Number	Notes
2	260DC17B-SS	
3	360DC17B-SS	
4	460DC17B-SS	
6	690FCH-DC17BSS	
8	890FCH-DC17BSS	
10	1090FCH-DC17BSS	
12	1290FCH-DC17BSS	

**Note:** 'B' suffix denotes clipper compatible component



## 2-12" DUAL CHAMBER FLOW CONDITIONING HOUSING PARTS

#9G Seal Bar

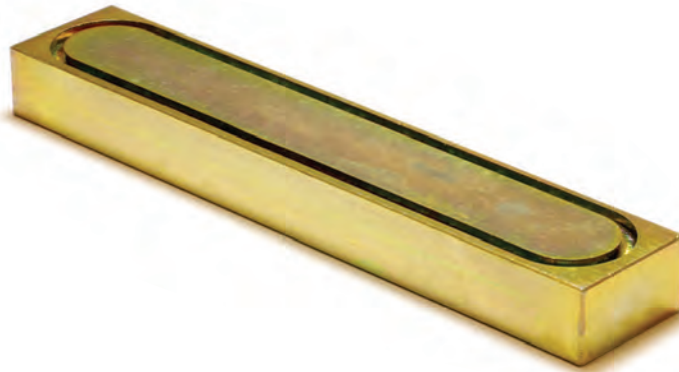

Available for 150 - 900, 1500 & 2500 ANSI ratings in 1018 YZP carbon steel. Requires one seal bar O-ring (#9B).

150 - 900 ANSI		1500 ANSI	2500 ANSI	
Model Size	Part Number	Part Number	Part Number	Notes
2	260DC09G	2250DC09G	2250DC09G	
3	360DC09G	3150DC09G	3250DC09G	
4	460DC09G	4150DC09G	4250DC09G	
6	690FCH-DC09G	Please Call	Please Call	
8	890FCH-DC09G	Please Call	Please Call	
10	1090FCH-DC09G	Please Call	Please Call	
12	1290FCH-DC09G	Please Call	Please Call	

#12 Clamping Bar



Available for 150 - 900 & 1500/2500 ANSI ratings in 1018 YZP carbon steel. Requires corresponding clamping bar screws (#11).

150 - 900 ANSI		1500 / 2500ANSI	
Model Size	Part Number	Part Number	Notes
2	260DC12	2250DC12	
3	360DC12	3250DC12	
4	460DC12	4250DC12	
6	690FCH-DC12	Please Call	
8	890FCH-DC12	Please Call	
10	1090FCH-DC12	Please Call	
12	1290FCH-DC12	Please Call	

\* 1500 & 2500 ANSI FCH models only available in 2"-4". For line sizes outside of this range please contact the factory

**VARIABLE BY MODEL SIZE**

**#18A Valve Seat - Grease Style**



This unit incorporates a machined grease port for slide valve lubrication. Requires one valve seat O-ring (#18FH), one valve seat grease seal (#18GH) and slide valve lubricant (#54).

**CF8M Stainless Steel**

	150 -900 ANSI	1500 ANSI	2500 ANSI	
Model Size	Part Number	Part Number	Part Number	Notes
2	260DC18A-SS	260DC18A-SS	2250DC18A-SS	
3	360DC18A-SS	360DC18A-SS	3250DC18A-SS	
4	460DC18A-SS	4150DC18A-SS	4250DC18A-SS	
6	690FCH-DC18A-SS	Please Call	Please Call	
8	890FCH-DC18A-SS	Please Call	Please Call	
10	1090FCH-DC18A-SS	Please Call	Please Call	
12	1290FCH-DC18A-SS	Please Call	Please Call	

**#18B Valve Seat - Soft Seat Style**



This unit incorporates a specially machined seal channel to help prevent O-ring dislocation. Requires two valve seat O-rings (#18FH).

**CF8M Stainless Steel**

	150 -900 ANSI	1500 ANSI	2500 ANSI	
Model Size	Part Number	Part Number	Part Number	Notes
2	260DC18B-SS	260DC18B-SS	2250DC18B-SS	
3	360DC18B-SS	360DC18B-SS	3250DC18B-SS	
4	460DC18B-SS	4150DC18B-SS	4250DC18B-SS	
6	690FCH-DC18B-SS	Please Call	Please Call	
8	890FCH-DC18B-SS	Please Call	Please Call	
10	1090FCH-DC18B-SS	Please Call	Please Call	
12	1290FCH-DC18B-SS	Please Call	Please Call	

\* 1500 & 2500 ANSI FCH models only available in 2"-4". For line sizes outside of this range please contact the factory

## 2-12" DUAL CHAMBER FLOW CONDITIONING HOUSING PARTS

#4A Body O-ring



HNBR Rubber

	150 - 900 ANSI	1500 ANSI	2500 ANSI
Model Size	Part Number	Part Number	Part Number
2	O257-80H	O362-80H	O362-80H
3	O365-80H	O364-80H	O0365-80H
4	O367-80H	O370-80H	O36880H
6	O373-80H	Please Call	Please Call
8	O378-80H	Please Call	Please Call
10	O378-80H	Please Call	Please Call
12	O381-80H	Please Call	Please Call

#18FH Valve Seat O-ring



HNBR Rubber

	150-2500 ANSI	
Model Size	Part Number	Notes
2	O236-80H	
3	O243-80H	
4	O248-80H	
6	O259-80H	
8	O266-80H	
10	O271-80H	
12	O275-80H	

#9B Seal Bar O-ring



HNBR Rubber

	150 - 900 ANSI	1500 ANSI	2500 ANSI
Model Size	Part Number	Part Number	Part Number
2	O238-80H	O345-80H	O345-80H
3	O247-80H	O427-80H	O348-80H
4	O250-80H	O434-80H	O353-80H
6	O260-80H	Please Call	Please Call
8	O266-80H	Please Call	Please Call
10	O271-80H	Please Call	Please Call
12	O276-80H	Please Call	Please Call

\* 1500 & 2500 ANSI FCH models only available in 2"-4". For line sizes outside of this range please contact the factory

**VARIABLE BY MODEL SIZE**

**#8H Flow Conditioner O-ring**



**HNBR Rubber**

Model Size	Part Number	Notes
2	O228-80H	
3	O235-80H	
4	O242-80H	
6	O259-80H	
8	O369-80H	
10	O378-80H	
12	O381-80H	

**#80H Flange Adaptor O-ring**



**HNBR Rubber**

Model Size	Part Number	Notes
2	O229-80H	
3	O238-80H	
4	O246-80H	
6	O363-80H	
8	O371-80H	
10	O378-80H	
12	O381-80H	

*Applies to SC and DC FCH models  
(2-4" DC FCH Models do not come with Flange Adaptor)*

**#33 Body Studs**



A193 YZP CS - B7M alloy bolting.

Short Studs			Long Studs	
Model Size	Part Number (QTY)	Notes	Part Number (QTY)	Notes
2	DC33S58-218-BS (11)		DC33S58-300-BS (3)	
3	DC33S58-214-BS (14)		DC33S58-318-BS (1)	
4	DC33S34-212-BS (14)		DC33S34-312-BS (1)	
6	DC33S34-300-BS (15)		DC33S34-338-BS (3)	
8	DC33S34-314-BS (21)		N/A	
10	DC33S1-334-BS (18)		N/A	
12	DC33S1-334-BS (18)		N/A	

YZP = Yellow Zinc Plated

*For all other replacement parts refer to the 2-12" Dual Chamber Orifice Fitting Parts*



**VANE TYPE FLOW CONDITIONERS**

# Contour<sup>TM</sup>

## Flow Conditioning Solutions

by **Canalta** 

**Contour<sup>TM</sup> Vane Flow Straighteners** are available in the traditional 1998 uniform concentric 19-tube bundle configuration. Sized and assembled to AGA 3 / API 14.3 and ISO 5167-1 specifications, these straightening vanes are effective in aiding the removal of flow swirl and turbulence caused by upstream piping arrangements. Available in 316 stainless steel as standard, the Contour<sup>TM</sup> Vane Flow Straightener is suitable for most process environments.

Flange-style straightening vanes are installed between two raised face or RTJ flanges upstream of the orifice plate. Available for pipe sizes 2" through 30" in all standard schedules, with custom schedules by special order.

Pin-style straightening vanes are line mounted with a 3/8" x 3/4" (16 UNC) set pin in the wall of the upstream pipe. Available for pipe sizes 2" through 30" in all standard schedules, with custom schedules by special order.

Contact one of our sales representatives today for full details, technical specifications and ordering information.

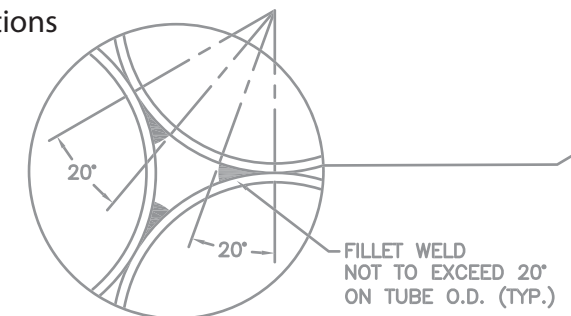

**TUBE WELD DETAIL**  
**END VIEW**  
TYP. AT ALL POINTS OF INTERSECTION  
BOTH ENDS

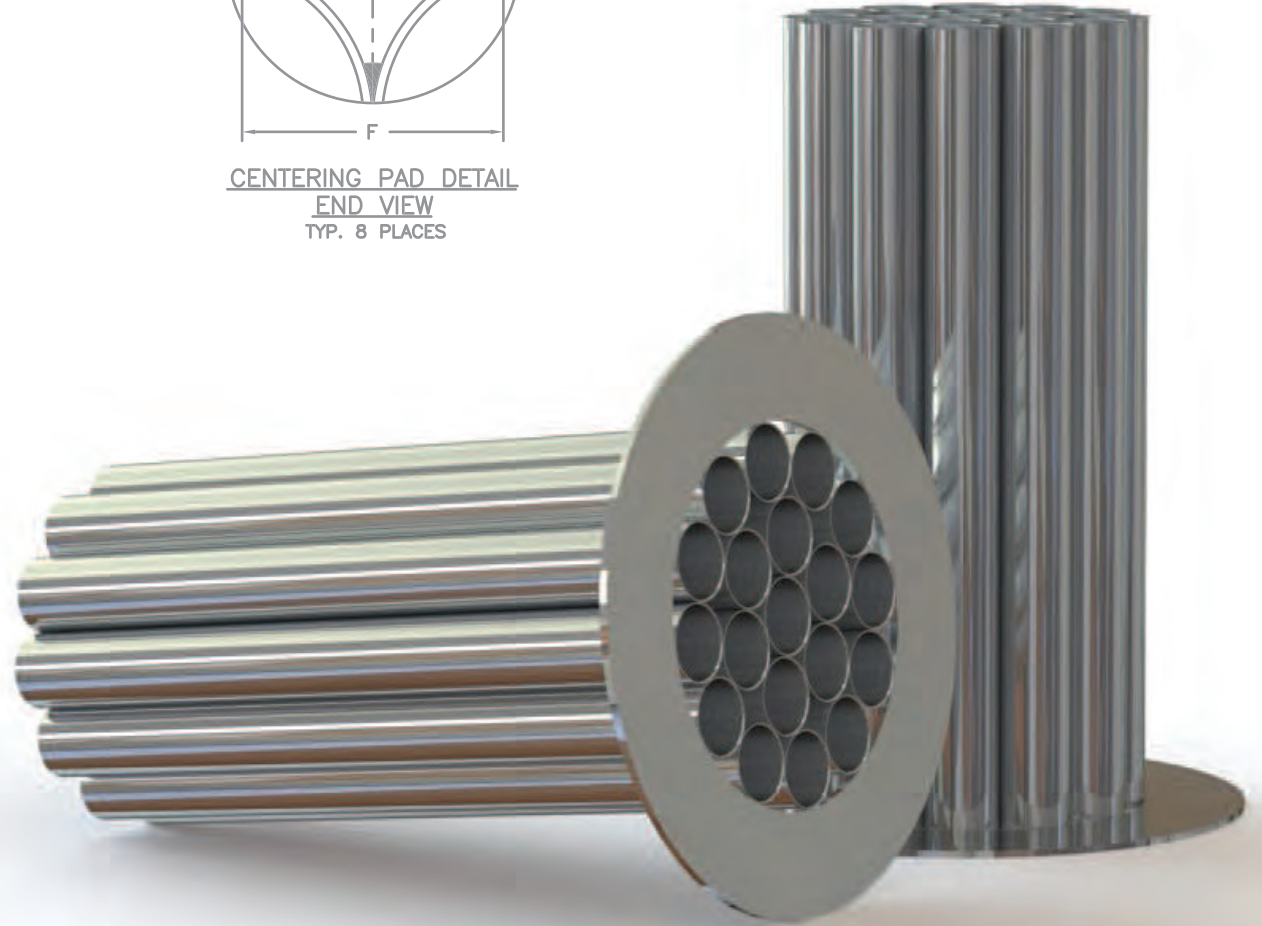
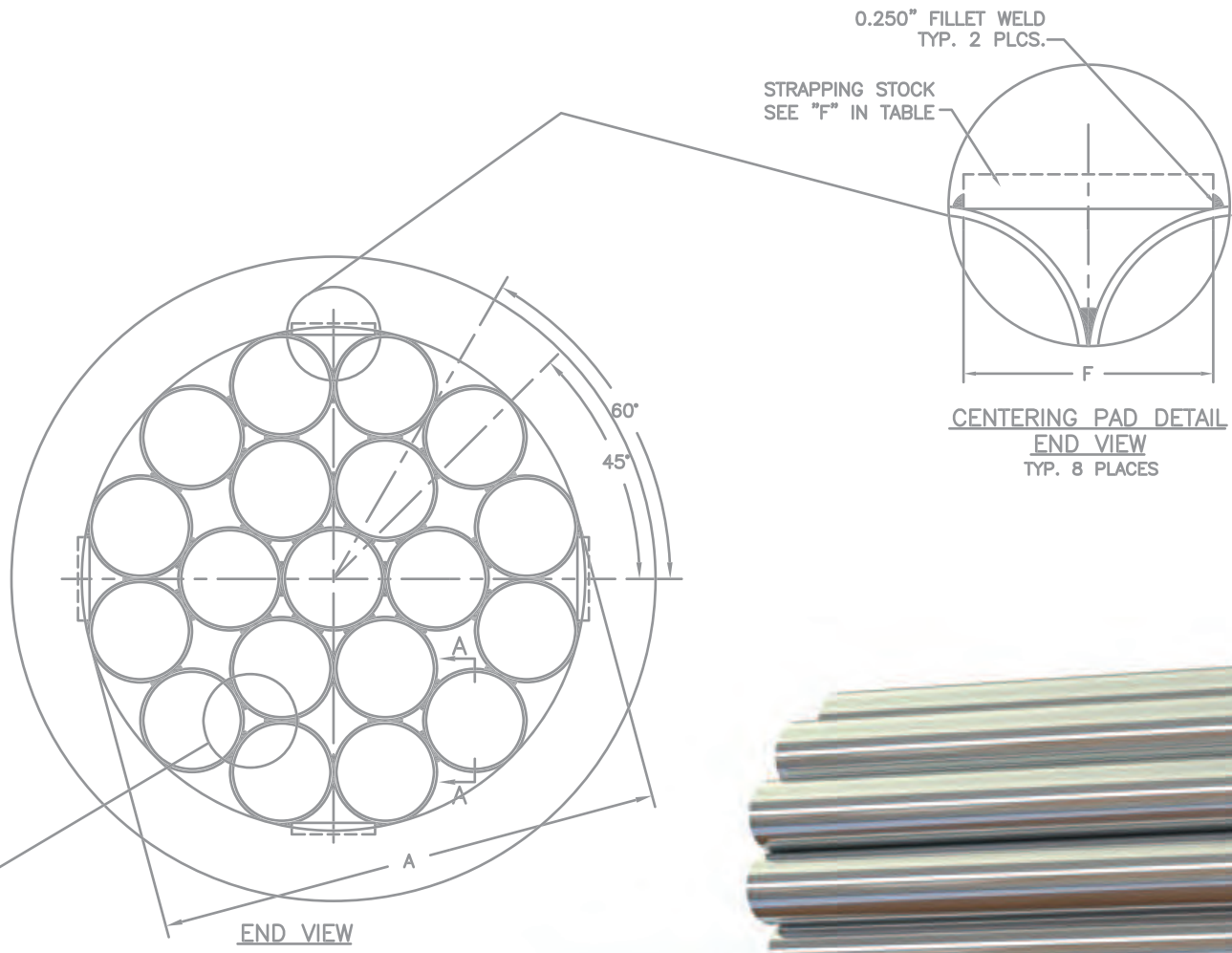

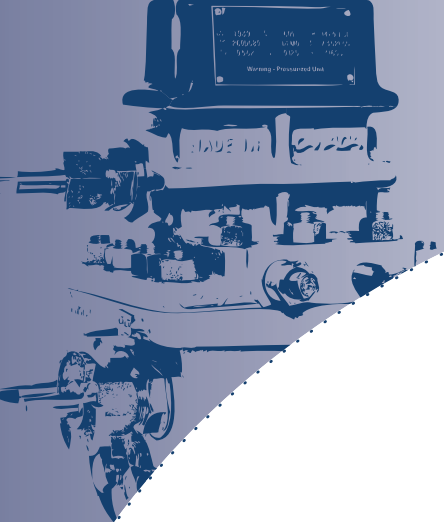

**NOTES**

## NOTES



# Canalta

## Flow Measurement

A Canalta Controls Company

---

### Canalta Flow Measurement's parts offerings support these high quality product lines:

- Double Block and Bleed Orifice Fittings
- Dual Chamber Orifice Fittings
- Single Chamber Orifice Fittings
- Flow Conditioner Housings
- Meter Runs
- Orifice Flange Unions



Corporate Head Office / Canada	(+1) 403 342 4494
United States	(+1) 940 898 0800
Argentina	(+54) 9 11 3272 2377
United Kingdom	(+44) (0) 1842 768350
Singapore	(+65) 6316 4965
India	(+91) 96004 55797

Find a list of our global distribution partners at [www.canaltaflow.com/global](http://www.canaltaflow.com/global)

Contact us today to find out more. Call Toll Free: 1.855.CANALTA

The "Canalta Flow Measurement", "Canalta Controls" and "Contour" names and logos are trademarks of Canalta Controls Ltd. All other trademarks are the property of their respective companies. All information presented here is for information purposes only. Though every effort has been made to ensure their accuracy, the contents of this publication shall not be construed as warranties or guarantees, expressed or implied, regarding the products or services described herein, or their use or applicability. Due to Canalta's commitment to quality and innovation, all product designs, specifications and information material, including the contents of this publication, are subject to change without notice. Responsibility for the proper selection, maintenance and use of any product remains with the customer. SAFETY FIRST.

Copyright, trademark and other forms of proprietary rights protect the contents of this publication.

© 2019 Canalta Controls Ltd. All rights reserved. Unauthorized reproduction in whole or in part is prohibited.