

Canalta

Flow Measurement

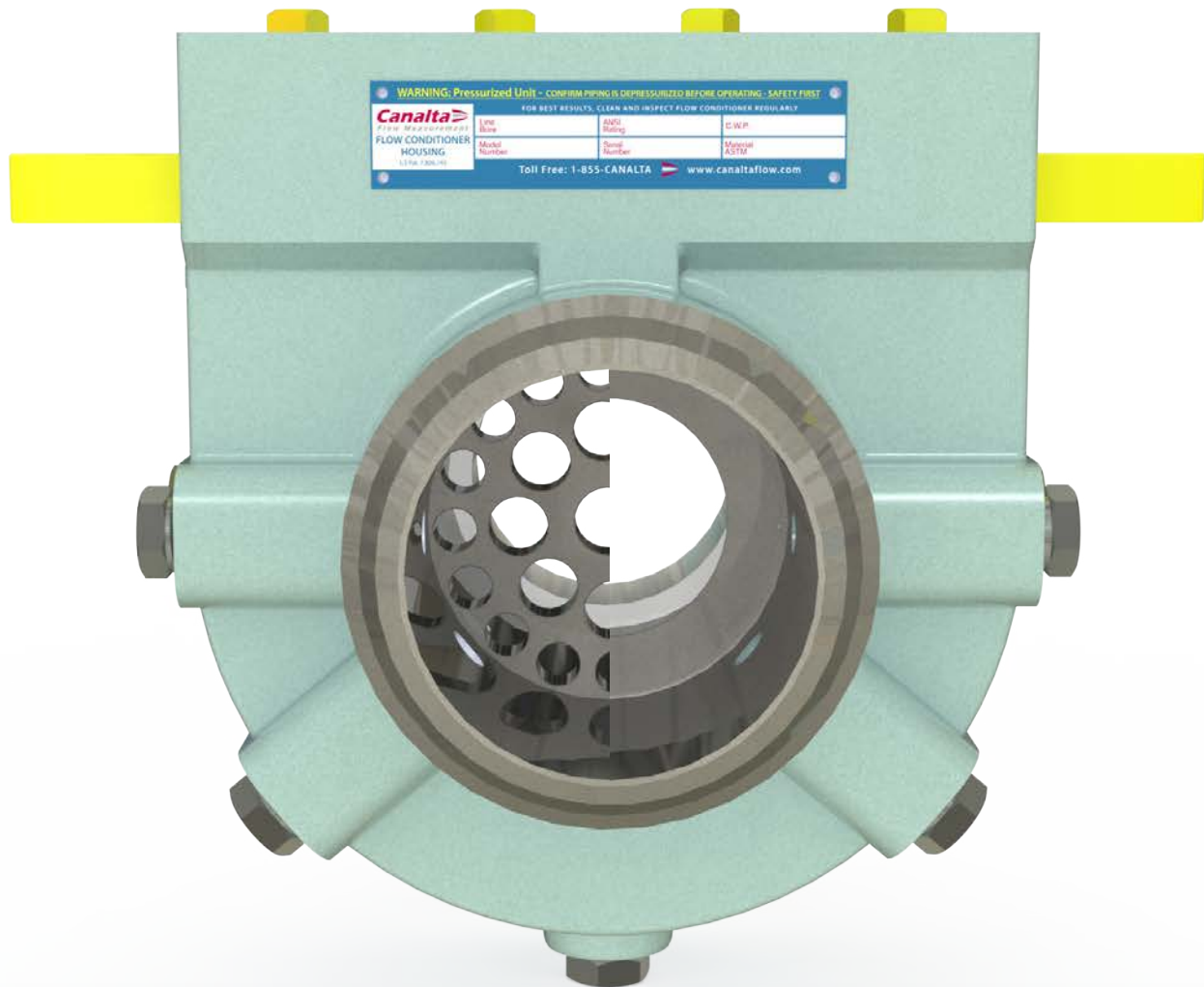

The Canalta Hybrid™

The versatile Flow Conditioner Housing which converts
to a Single Chamber Orifice Meter

*Innovative Design for First Class
Accuracy, Reliability and Performance*

Call Us Toll Free: 1-855-CANALTA

An ISO 9001:2015 registered company

Phone: 403.342.4494

Email: sales@canaltaflow.com

www.canaltaflow.com

Key Features:

Canalta offers the **Hybrid™**; a Canalta Flow Conditioner Housing utilized as a Single Chamber Orifice Fitting. The *Canalta Hybrid™* Single Chamber enables the ease, safety and practicality of inspecting and changing of an orifice plate the same way it is used as a Canalta Flow Conditioner Housing (FCH). The unit is the same body design as the Canalta FCH with tap connections for primary and secondary measurement and use of an orifice plate.

- The *Canalta Hybrid™* covers the following sizes: 2", 3" & 4" 150-900 ANSI. One meter suits all pressure ratings from 150-900 ANSI avoiding unnecessary machining costs.
- The bespoke design integral flange is welded to the downstream spool piece and bolts straight onto the *Hybrid™* body providing exact concentricity.
- The Orifice Plate carrier and operation is the same as a standard Single Chamber unit.
- The seal between the *Hybrid™* body and the integral flange is guaranteed by use of O-rings positioned on the weldneck. 2" has 1 O-ring seal, 3" and 4" have 2 O-ring seals.

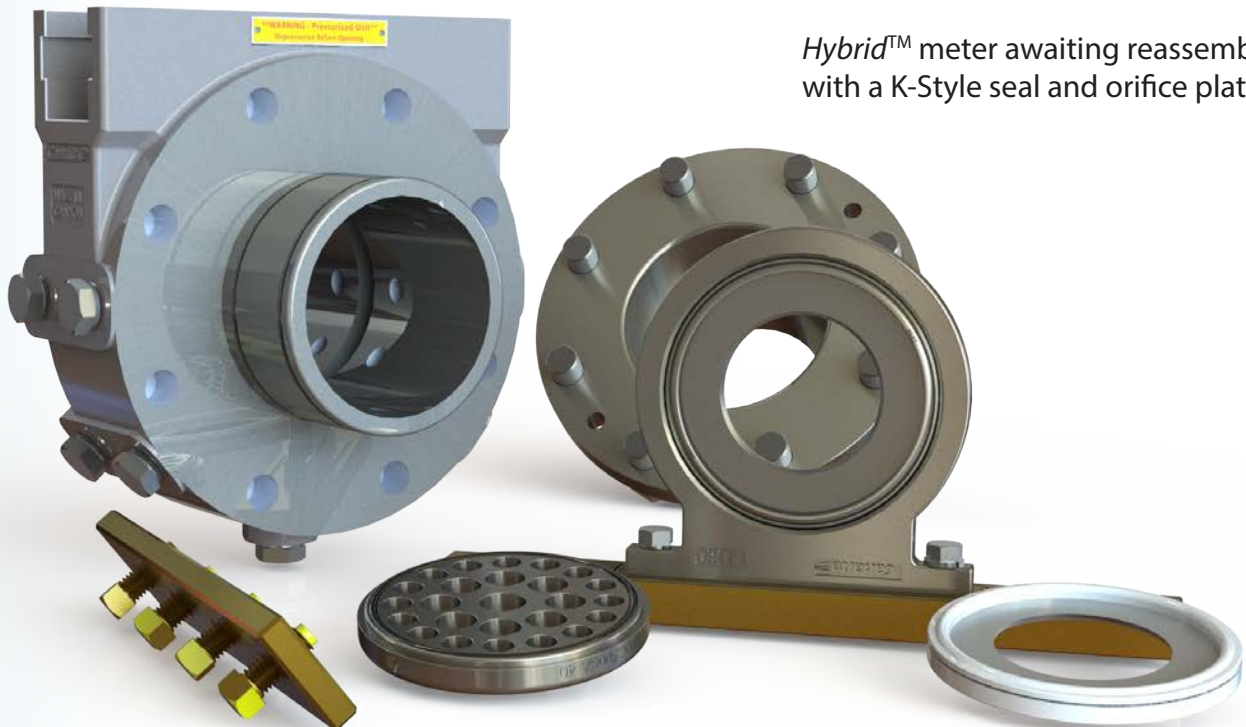

Hybrid™ meter awaiting reassembly with a K-Style seal and orifice plate

ACCURACY, RELIABILITY, PERFORMANCE.

The **Canalta Hybrid™ Single Chamber** allows the use of an orifice plate for accurate measurement meeting AGA 3 and ISO 5167 measurement standards. Same as the Canalta Single Chamber, it ensures that the vital length of tube between the flow conditioner and orifice plate is flawlessly constructed according to the required specification.

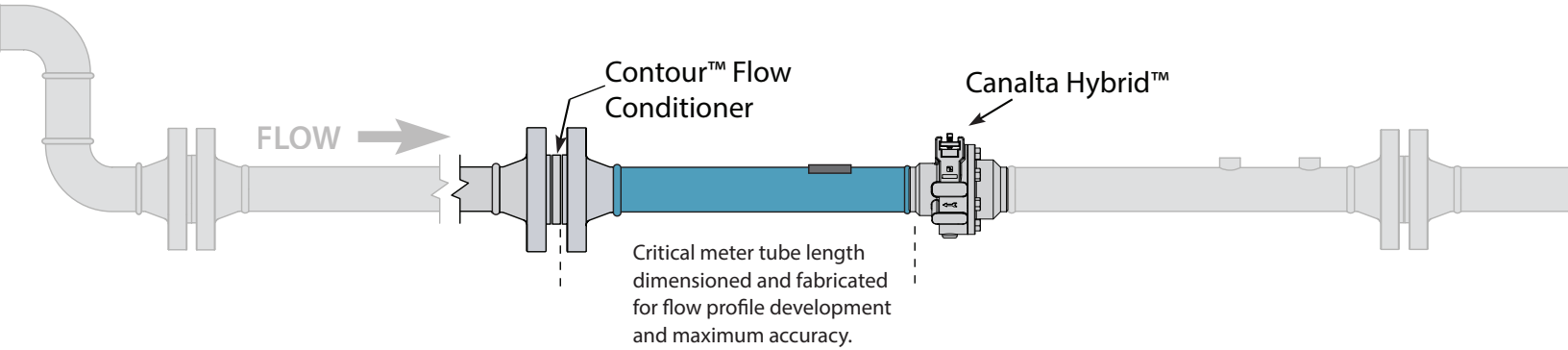

Weights & Dimensions:

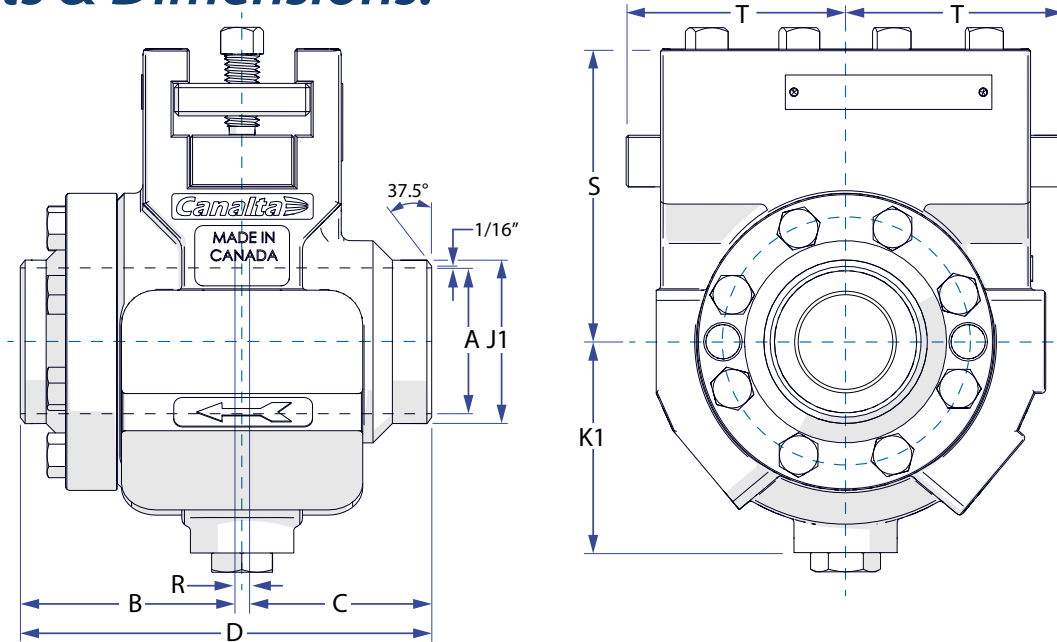

SIZE	ANSI	Standard Pipe Sch.	Upstream Face of Orifice Plate to Upstream Face of (end type)	Downstream Face of Orifice Plate to Downstream Face of Flange	Overall Face to Face	Pipe O.D at point of welding	Centerline to Bottom	Orifice Plate Thickness	Centerline to Top	Operating Clearance from Center	Approximate Weight (Pounds)	SIZE
Flange Upstream x Weldneck Downstream												
2	150-900	40,80	3.145	2.699	5.969	2.375	3.063	0.125	4.250	3.188	25	2
3	150-900	40,80	4.521	3.199	7.845	3.500	4.058	0.125	4.837	4.183	45	3
4	150-900	40,80	5.798	3.522	9.985	4.500	4.907	0.125	5.313	4.938	70	4



TECHNICAL SPECIFICATIONS

Design	Orifice fittings supplied in Canada are built in accordance with the ABSA Quality Control Program and carry a CRN registration number. Industry Canada Approval Number AF-0014. In compliance with ASME 16.34 and ASME 16.5, ASTM specifications, AGA-3 Latest Edition and ISO-5167.
Body Materials	A216 WCB, A216 WCC, A352 LCC, A358 CF8M, A995 Gr4A, A995 Gr6A, Custom
Internal Parts	AISI 316 or A351 Stainless Steel, Custom
Sizes and ANSI Class	2", 3" and 4" 900 ANSI rated integral flange connection with unique seal
Connections	Integral Flange x Weldneck
Internal Bore Sizes	40, 60, 80, 100, 120, 160 and custom sizes
Sealing Compounds	Seal bar - HNBR O-ring standard, gasket optional Orifice plate seals - Type "K" 2000 Edition formed HNBR seal on a 316 SS retainer ring, Notched HNBR seal. (<i>Other options are available upon request, please call our sales team</i>) Integral Flange - HNBR O-ring
Line Bore I.D. Tolerance	In conformance with AGA-3 and ISO-5167 Latest Editions
Eccentricity Repeatability	In conformance with AGA-3 and ISO-5167 Latest Editions
Tap Connections	Telemetry Taps as standard (Two pairs of 1/2" NPT per side), One pair per side optional 2" and 3" fitting sizes center bored to .375" inside diameter 4" and larger sizes center bored to .500" inside diameter Tolerance +/- 1/64"
Orifice Plate Seal Gap	2" through 4" = 0.562"
Operating Temperature	Standard at -20° to 100° F, optional -40° to 1200° F
Operating Position	Vertical or horizontal

Conformance

All fittings come standard with a documentation package including hydro-test, function test, inner valve seal test, quality control inspection and material test reports. Traceability is maintained in accordance with the ISO-9001 Quality Control Program. The fittings are manufactured within the guidelines of ASME 16.34 and ASME 16.5. When required, radiography, stress relief, ultra-sonic and liquid dye penetration tests can be performed with the relevant report submitted.

Reporting

An AGA 2000 inspection report is included with the purchase of every fitting. The documented tests include:

- | | | |
|------------------------|---------------------------|---------------------------|
| • I.D. Bore Tolerance | • Instrument Tap Diameter | • Instrument Tap Location |
| • Tap Communication | • Plate Seal Test | • Seal Protrusion |
| • Orifice Eccentricity | • Bore Inside Diameter | • Bore Roughness |



Call Us Toll Free: 1-855-CANALTA
Phone: 403.342.4494
Email: sales@canaltaflow.com
www.canaltaflow.com